



Digital Semiconductor SA-110 Microprocessor

Technical Reference Manual

Order Number: EC-QPWLC-TE

Revision/Update Information:

This is revision C of a preliminary document. It supersedes the *Digital Semiconductor SA-110 Microprocessor Technical Reference Manual* (EC-QPWLB-TE). This manual is to be used in conjunction with *ARM Architectural Reference* (EC-QV44A-TE).

October 1996

While Digital believes the information included in this publication is correct as of the date of publication, it is subject to change without notice.

Digital Equipment Corporation makes no representations that the use of its products in the manner described in this publication will not infringe on existing or future patent rights, nor do the descriptions contained in this publication imply the granting of licenses to make, use, or sell equipment or software in accordance with the description.

© Digital Equipment Corporation 1996. All rights reserved.
Printed in U.S.A.

Digital, Digital Semiconductor, and the DIGITAL logo are trademarks of Digital Equipment Corporation.

Digital Semiconductor is a Digital Equipment Corporation business.

ARM and ARM Powered are trademarks of Advanced RISC Machines Ltd.

All other trademarks and registered trademarks are the property of their respective owners.



SA-110 Microprocessor

The Digital Semiconductor SA-110 Microprocessor (SA-110) is the first member of the StrongARM family of high-performance, low-power microprocessors. The SA-110 is an implementation of Advanced RISC Machines Ltd. (ARM) Version 4 architecture and offers significant advances in microprocessor design. The SA-110 has been designed to further extend the ARM family as the world's leading source of low-power, high-performance RISC processors for embedded consumer markets such as portable products and interactive digital video.

The SA-110 is a general-purpose, 32-bit RISC microprocessor with a 16KB instruction cache (Icache); a 16KB write-back data cache (Dcache); a write buffer; and a memory-management unit (MMU) combined in a single chip. The five-stage pipeline distributes tasks evenly over time to remove bottlenecks, ensuring high throughput for the core logic. The SA-110 offers high-level RISC performance, yet it provides minimal power consumption, making it ideal for portable, low-cost systems.

The SA-110 onchip MMU supports a conventional two-level page-table structure, with a number of extensions, which makes it ideal for embedded control systems and object-oriented systems. These features result in a high instruction throughput and impressive real-time response for a small and cost-effective chip.

Features

- High performance
 - 115 Dhrystone 2.1 MIPS @100 MHz
 - 185 Dhrystone 2.1 MIPS @160 MHz
 - 192 Dhrystone 2.1 MIPS @166 MHz
 - 230 Dhrystone 2.1 MIPS @200 MHz
 - 268 Dhrystone 2.1 MIPS @233 MHz
- Low power (normal mode)
 - 130 mW @ 1.65 V/100 MHz core/27 MHz bus
 - 170 mW @ 1.65 V/160 MHz core/33 MHz bus
 - 230 mW @ 2.0 V/166 MHz core/33 MHz bus
 - 330 mW @ 2.0 V/200 MHz core/50 MHz bus
 - 420 mW @ 2.0 V/233 MHz core/66 MHz bus
- Internal phase-locked loop (PLL)
 - 3.68 or 3.56 MHz external reference oscillator
- Idle and sleep power-down modes
- Big and little endian operating modes
- 3.3-V I/O interface
- 144-pin thin quad flat pack (TQFP)
- 32-way set-associative caches
 - 16KB instruction cache
 - 16KB write-back data cache
- 32-entry memory-management units
 - Maps 4KB, 64KB, or 1MB
- Write buffer
 - 8 entry 16-bytes each
- Early termination 32-bit multiplier
 - 32-bit accumulation - (2-4 cycles)
 - 64-bit accumulation - (3-5 cycles)
- Memory bus
 - Asynchronous or synchronous
 - 0-33 MHz @ 100 MHz
 - 0-53 MHz @ 160 MHz
 - 0-53 MHz @ 166 MHz
 - 0-66 MHz @ 200 MHz
 - 0-66 MHz @ 233 MHz

Applications

- Portable products
 - Personal Digital Assistants (PDAs)
 - Smart phones
 - Digital cameras
 - Organizers
 - Bar-code scanners
- Interactive digital media
 - Digital set-top devices
 - Interactive TV
 - Video game players
- Embedded control
 - Internetworking: routers, bridges, LAN switches
 - Office automation: printers, scanners, copiers
 - Telecommunication: PBX, Cellular Base Station
 - Storage peripherals: drive and RAID controllers
 - PC add-ins: intelligent I/O cards, LAN/WAN
- Network computers
 - Tablet intranet products
 - Internet appliances

Table of Contents

1.0 Introduction.....	1
1.1 ARM Architecture.....	2
1.1.1 26-Bit Mode.....	2
1.1.2 Coprocessors.....	2
1.1.3 Memory Management.....	2
1.1.4 Instruction Cache.....	2
1.1.5 Data Cache.....	2
1.1.6 Write Buffer.....	2
1.2 Block Diagram.....	3
1.3 Functional Diagram.....	4
2.0 Signal Description.....	5
3.0 ARM Implementation Options.....	8
3.1 Big and Little Endian.....	8
3.2 Exceptions.....	8
3.2.1 Reset.....	9
3.2.2 Abort.....	9
3.2.3 Vector Summary.....	10
3.2.4 Exception Priorities.....	10
3.2.5 Interrupt Latencies.....	11
3.3 Coprocessors.....	11
4.0 Instruction Set.....	12
4.1 Instruction Set.....	12
4.2 Instruction Timings.....	12
5.0 Configuration.....	13
5.1 Internal Coprocessor Instructions.....	13
5.2 Registers.....	14
5.2.1 Register 0 – ID.....	14
5.2.2 Register 1 – Control.....	15
5.2.3 Register 2 – Translation Table Base.....	16
5.2.4 Register 3 – Domain Access Control.....	16
5.2.5 Register 4 – Reserved.....	16
5.2.6 Register 5 – Fault Status.....	16
5.2.7 Register 6 – Fault Address.....	16
5.2.8 Register 7 – Cache Control Operations.....	17
5.2.9 Register 8 – TLB Operations.....	17
5.2.10 Registers 9 -14 Reserved.....	17
5.2.11 Registers 15 – Test, Clock and Idle Control.....	18
5.2.11.1 Icache LFSR Controls.....	18
5.2.11.2 Clock Controls.....	18
6.0 Caches and Write Buffer.....	19
6.1 Instruction Cache (Icache).....	19
6.1.1 Icache Operation.....	19
6.1.2 Icache Validity.....	19

Table of Contents

6.1.2.1	Software Icache Flush.....	19
6.1.3	Icache Enable/Disable and Reset	19
6.1.3.1	Enabling the Icache.....	19
6.1.3.2	Disabling the Icache	20
6.2	Data Cache (Dcache).....	20
6.2.1	Cacheable Bit – C.....	20
6.2.2	Bufferable Bit - B.....	20
6.2.3	Dcache Operation.....	20
6.2.3.1	Cacheable Reads C = 1	20
6.2.3.2	Noncacheable Reads C = 0	20
6.2.4	Dcache Validity.....	21
6.2.4.1	Software Dcache Flush.....	21
6.2.4.2	Doubly Mapped Space.....	21
6.2.5	Dcache Enable/Disable and Reset.....	21
6.2.5.1	Enabling the Dcache	22
6.2.5.2	Disabling the Dcache	22
6.3	Write Buffer (WB)	22
6.3.1	Bufferable Bit.....	22
6.3.2	Write Buffer Operation	22
6.3.2.1	Writes to a Bufferable and Cacheable Location (B=1,C=1).....	22
6.3.2.2	Writes to Bufferable and Noncacheable Location (B=1,C=0)	22
6.3.2.3	Unbufferable Writes (B=0).....	23
6.3.3	Enabling the Write Buffer	23
6.3.4	Disabling the Write Buffer.....	23
7.0	Memory Management Unit (MMU)	24
7.1	Overview	24
7.1.1	MMU Registers.....	24
7.2	MMU Faults and CPU Aborts.....	24
7.3	External Aborts.....	24
7.3.1	Cacheable Reads (Cache Line Fills)	25
7.3.2	Buffered Writes.....	25
7.4	Interaction of the MMU, Icache, Dcache and Write Buffer.....	25
8.0	SA-110 Clocking.....	27
8.1	SA-110 Operating Modes.....	27
8.2	SA-110 Clocking.....	27
8.2.1	Switching to Idle Mode.....	27
8.2.2	Switching to Sleep Mode	28
8.2.3	Core Clock Configuration - CCCFG.....	28
8.2.4	Memory Clock Configuration - MCCFG.....	29
8.2.5	Tester and Debug Clocks	29
9.0	Bus Interface	30
9.1	Bus Modes	30
9.1.1	Standard and Enhanced Mode.....	30
9.2	SA-110 Bus Stalls.....	31
9.3	Cycle Types	32
9.4	Memory Access	32

Table of Contents

9.5 Read/Write.....	32
9.6 Address Pipeline Enable (APE).....	32
9.7 Memory Access Types	33
9.8 External Accesses.....	34
9.8.1 Unbuffered Writes / Noncacheable Reads	34
9.9 Buffered Write.....	35
9.10 Cache Line Fill	35
9.11 Read-Lock-Write.....	35
9.12 Stalling the Bus.....	36
9.13 Summary of Transactions.....	37
9.13.1 Read Bursts	37
9.13.2 Write Bursts	37
9.13.3 Transaction Summary	37
10.0 Boundary Scan Test Interface	39
10.1 Overview	39
10.2 Reset	40
10.3 Pullup Resistors	41
10.4 nPWRSLP.....	41
10.5 Instruction Register	41
10.6 Public Instructions	41
10.6.1 EXTEST (00000)	41
10.6.2 SAMPLE/PRELOAD (00001).....	42
10.6.3 CLAMP (00100)	42
10.6.4 HIGHZ (00101).....	42
10.6.5 IDCODE (00110).....	43
10.6.6 BYPASS (11111).....	43
10.7 Test Data Registers.....	44
10.7.1 Bypass Register.....	44
10.7.2 SA-110 Device Identification (ID) Code Register.....	45
10.7.3 SA-110 Boundary Scan (BS) Register.....	45
10.8 Boundary Scan Interface Signals.....	46
11.0 dc Parameters	51
11.1 Absolute Maximum Ratings.....	51
11.2 dc Operating Conditions.....	51
11.3 dc Characteristics.....	52
11.4 Power Supply Voltages and Currents.....	52
12.0 ac Parameters	53
12.1 Test Conditions.....	53
12.2 Module Considerations.....	53
12.3 Main Bus Signals.....	54
12.4 SA-110 ac Parameters	56
13.0 Physical Details.....	62
13.1 Pinout.....	63
Support, Products and Documentation	

Figures

1 SA-110 Block Diagram.....	3
2 Functional Diagram.....	4
3 Read or Write (One Word).....	33
4 Sequential Read or Write (Two Word)	33
5 Two 1-Word Nonsequential Reads or Writes Back-to-Back.....	34
6 Cache Line Fill.....	35
7 Read-Lock-Write.....	36
8 Using nWAIT to Stop the SA-110 for One MCLK Cycle.....	36
9 Test Access Port (TAP) Controller State Transitions	40
10 Boundary Scan Block Diagram.....	44
11 Boundary Scan General Timing.....	46
12 Boundary Scan Tri-state Timing.....	47
13 Boundary Scan Reset Timing.....	47
14 SA-110 Main Bus Timing.....	54
15 SA-110 Address Timing with APE=Low	55
16 SA-110 Address Timing with APE=HIGH	55
17 SA-110 144-Pin TQFP Mechanical Dimensions in mm.....	62

Tables

1	Signal Pin Description	5
2	Vector Summary	10
3	Instruction Timings	12
4	Cache & MMU Control Registers	14
5	Cache Control Operations	17
6	TLB Control Operations	17
7	Test, Clock, and Idle Controls	18
8	Valid MMU, Dcache & Write Buffer Combinations.....	25
9	CCLK Configurations	28
10	MCLK Configurations	29
11	Enhanced Mode Wrapping Order	30
12	Byte Mask	31
13	Cycle Type Encodings	32
14	SA-110 Transactions.....	37
15	SA-110 Boundary Scan Interface Timing.....	48
16	Boundary Scan Signals & Pins	49
17	SA-110 dc Maximum Ratings.....	51
18	SA-110 dc Operating Conditions.....	51
19	SA-110 dc Characteristics.....	52
20	SA-110 Power Supply Voltages and Currents	52
21	SA-110 Output Derating	53
22	SA-110 ac for –AA Parts	57
23	SA-110 ac for –BA Parts	58
24	SA-110 ac for –CA Parts	59
25	SA-110 ac for –DA Parts	60
26	SA-110 ac for –EA Parts.....	61
27	SA-110 Pinout – 144 pin Thin Quad Flat Pack	63

1.0 Introduction

The SA-110 microprocessor (SA-110) is a general purpose 32-bit microprocessor with a 16KB instruction cache, a 16KB writeback data cache, an 8-entry write buffer with 16 bytes per entry, and a memory management unit (MMU) combined in a single chip. The SA-110 is software compatible with the ARM V4 architecture processor family and can be used with ARM support chips such as I/O, memory and video.

The onchip caches together with the write buffer substantially raise the average execution speed and reduce the average amount of memory bandwidth required by the processor. This allows the external memory to support additional processors or direct memory access (DMA) channels with minimal performance loss.

The instruction set comprises eight basic instruction types:

- Two of these make use of the onchip arithmetic logic unit, barrel shifter and multiplier to perform high-speed operations on the data in a bank of 16 logical (31 physical) registers, each 32 bits wide.
- Three classes of instructions control data transfer between memory and the registers, one optimized for flexibility of addressing, another for rapid context switching and the third for swapping data.
- Two instructions control the flow and privilege level of execution.
- One class is used to access the privileged state of the machine.

The ARM instruction set is a good target for compilers of many different high-level languages. Assembly code programming, where required for critical code segments, is also straightforward unlike some RISC processors which depend on sophisticated compiler technology to manage complicated instruction interdependencies.

The memory interface has been designed to allow the performance potential to be realized without incurring high costs in the memory system. Speed-critical control signals are pipelined to allow system control functions to be implemented in standard low-power logic, and these control signals permit the exploitation of page mode access offered by industry standard DRAMs.

The SA-110 is a static part and has been designed to run at a reduced voltage to minimize its power requirements. This makes it ideal for portable applications where both these features are essential.

Document Conventions:

- | | |
|-------------|--|
| 0x | - marks a Hexadecimal quantity |
| BOLD | - external signals are shown in bold capital letters |
| binary | - where it is not clear that a quantity is binary it is followed by the word binary. |

Introduction

1.1 ARM Architecture

The SA-110 implements the ARM V4 architecture as defined in the *ARM Architecture Reference*, Version A, 7 Feb. 1996, with the following options.

1.1.1 26-Bit Mode

The SA-110 supports 26-bit mode but all exceptions are initiated in 32-bit mode. The P and D bits do not affect the operation of SA-110; they always read as a one and writes to them are ignored.

1.1.2 Coprocessors

The SA-110 only supports MCR and MRC access to coprocessor number 15. These instructions are used to access the memory management, configuration, and cache control registers. All other coprocessor instructions cause an undefined instruction exception. No support for external coprocessors is provided.

1.1.3 Memory Management

Memory management exceptions preserve the base address registers so no *fixup* code is required. Separate translation look aside buffers (TLBs) are implemented for the instruction and data streams. The TLBs each have 32 entries that can each map a segment, a large page, or a small page. The TLB replacement algorithm is round robin. The data TLBs support both the flush-all and flush-single-entry operation, while the instruction TLBs only support the flush-all operation.

1.1.4 Instruction Cache

The SA-110 has a 16KB instruction cache (Icache) with 32-byte blocks and 32-way associativity. The Icache supports the flush-all-entry function. Replacement is round robin within a set. The Icache can be enabled while memory management is disabled. When memory management is disabled all of memory is considered cacheable by the Icache.

1.1.5 Data Cache

SA-110 has a 16KB data cache (Dcache) with 32-byte blocks and 32-way associativity. The Dcache supports the flush-all, flush-entry, and copyback-entry functions. The copyback-all function is not supported in hardware. This function can be provided by software. The cache is read allocate with round-robin replacement.

1.1.6 Write Buffer

The SA-110 has a 8-entry write buffer with each entry able to contain 1 to 16 bytes. The drain-writebuffer operation is supported.

1.2 Block Diagram

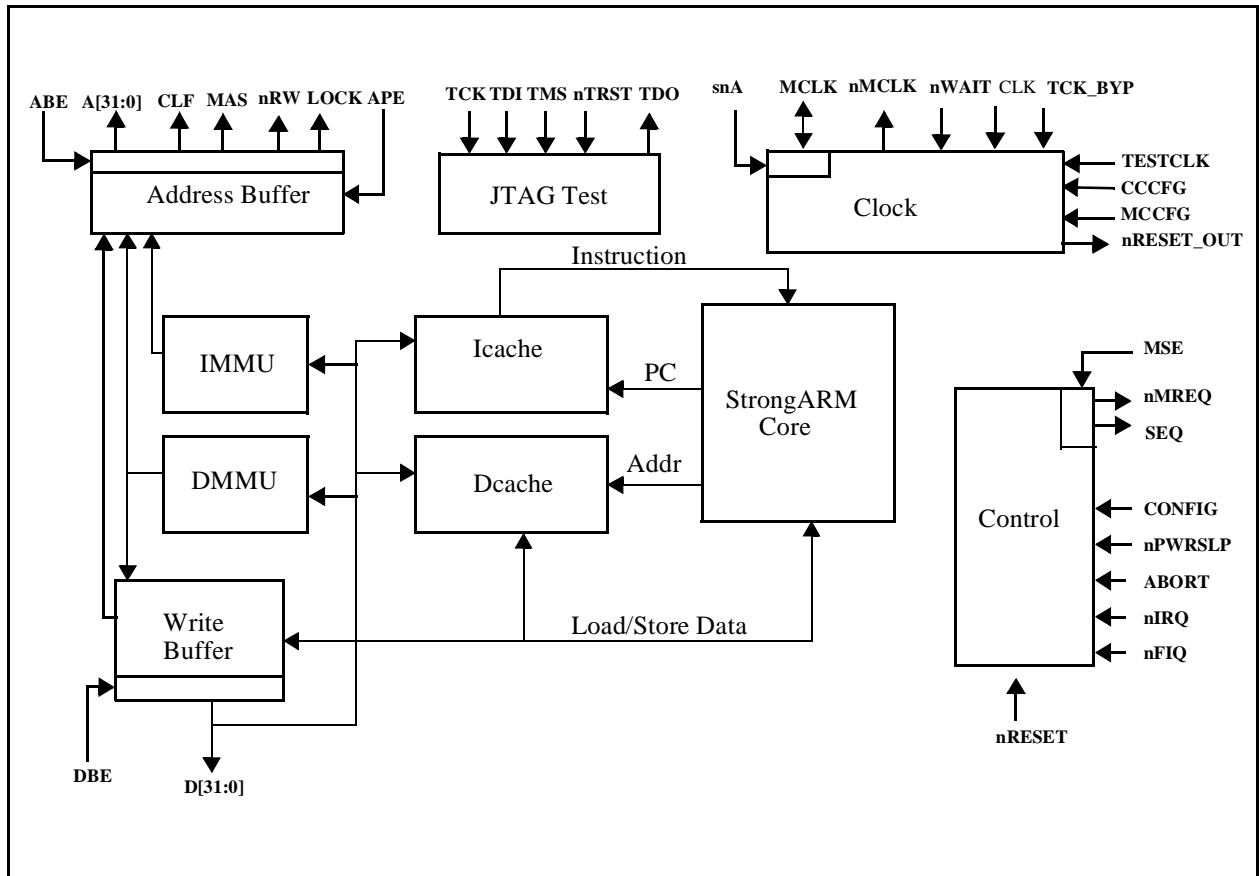

Figure 1: SA-110 Block Diagram

Introduction

1.3 Functional Diagram

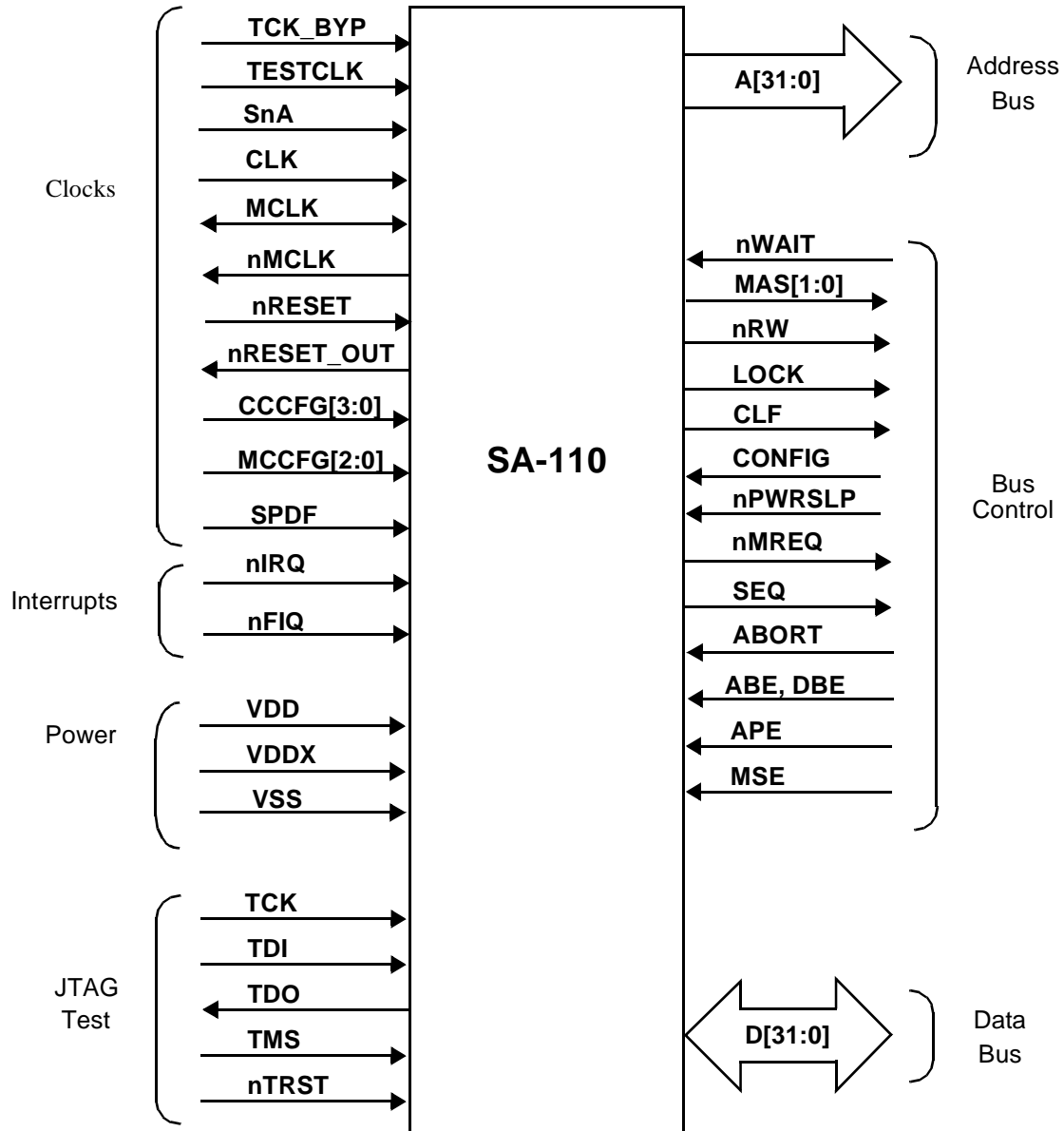

Figure 2: Functional Diagram

2.0 Signal Description

Table 1: Signal Pin Description

Name	Type	Description
A[31:0]	OCZ	Address Bus. This bus signals the address requested for memory accesses. If APE is high the address changes while MCLK is high, if APE is low the address changes during the following low period of MCLK . In enhanced bus mode A[1:0] contain byte mask bits two and three. The byte mask bits are asserted low on reads to indicate the required data. The byte mask bits are asserted low on writes to signal which bytes of the 32-bit data bus contain data to be accessed. In standard mode A[1:0] contain the low order two bits of the address. In both modes A[31:2] contain the upper 30 bits of the byte address.
ABE	IC	Address bus enable. When this input is low, the address bus A[31:0] , nRW , MAS[1:0] , CLF , and LOCK are put into a high impedance state (Note 1).
ABORT	IC	External abort. Allows the memory system to tell the processor that a requested access has failed. Only monitored when the SA-110 is accessing external memory.
APE	IC	Address pipeline enable. This input is used to control the timing of the latches on the address bus A[31:0] , MAS[1:0] , nRW , CLF , and LOCK . Normally these signals change during MCLK high, but they may be held to the next MCLK low by driving APE low. APE is a static configuration pin and must remain stable at all times.
CCCFG[3:0]	IC	Core Clock Configuration pins. These four pins configure the core clock speed. They must remain stable at all times.
CLF	OCZ	Cache Line Fill. An output signal used by the processor to indicate a cache line fill burst read or write. The CLF pin is asserted for full 8-word reads and writes. Burst reads are only done for cache line fills. Burst writes are done for castouts of dirty data and data stores that have merged in the write buffer. If CONFIG is high, then cache line fetches are wrapped in the four word subblock and then switched to the other subblock. The CLF signal follows address bus timing. Note it is NOT asserted for writes in pass one parts.
CLK	IC	The 3.57/3.68 MHZ crystal oscillator input clock for the core PLL. This is the base clock in from which the high speed core clock and the MCLK in synchronous mode are generated.
CONFIG	IC	The CONFIG input sets the bus mode to standard (low) or enhanced (high). In standard mode all cache line fetches start at word 0 of the cache block and stores are not allowed to merge. If CONFIG is high then cache line fetches are wrapped in the four word subblock then switch to the other subblock starting at the critical word. The write buffer is allowed to merge stores to the same cache block and will use the A[1:0] and MAS[1:0] pins to present a byte mask of the bytes being read or written. The CONFIG signal must remain stable at all times.
D[31:0]	ICOCZ	Data bus. These are bi-directional pins used for data transfers between the processor and external memory. For read operations (when nRW is low), the input data must be valid before the falling edge of MCLK . For write operations (when nRW is high), the output data will become valid while MCLK is low.
DBE	IC	Data bus enable. When this input is low, the data bus, D[31:0] is put into a high impedance state (Note 1). The drivers will always be high impedance except during write operations, and DBE must be driven high in systems which do not require the data bus for DMA or similar activities.

Signal Description

Table 1: Signal Pin Description

Name	Type	Description
LOCK	OCZ	Locked operation. LOCK is driven high, to signal a “locked” memory access sequence, and the memory manager should wait until LOCK goes low before allowing another device to access the memory. LOCK changes while MCLK is high and remains high during the locked memory sequence. The LOCK signal follows address bus timing.
MAS[1:0]	OCZ	Memory access size. An output signal used by the processor in standard bus mode to indicate to the external memory system the number of bytes being transferred. MAS[1:0] is 2 for word transfers, 1 for halfword transfers, and 0 for byte transfers, and is valid for both read and write operations. In enhanced mode the MAS pins contain bits zero and one of the byte mask. The byte mask bits are asserted low on reads to indicate the required data. The byte masks bits are asserted low on writes to signal which bytes of the 32-bit data bus contain data to be accessed. The MAS signals follow address bus timing.
MCCFG[2:0]	IC	Memory Clock Configuration pins. These pins configure the system clock speed when SnA is asserted. They must remain stable at all times and may not be dynamically changed. When SnA is asserted MCLK is generated by dividing the core clock by the value of MCCFG plus two (2..9) for MCCFG in the range 0..7.
MCLK	ICOCZ	Memory clock input or output. When SnA is deasserted MCLK is an input clock, when SnA is asserted MCLK is an output. This clock times all SA-110 memory accesses. The low or high period of MCLK may be stretched for slow peripherals; alternatively, the nWAIT input may be used with a free-running MCLK to achieve similar effects.
MSE	IC	Memory request/sequential enable. When this input is low, the nMREQ and SEQ outputs are put into a high impedance state (Note 1).
nFIQ	IC	Not fast interrupt request. If FIQs are enabled, the processor will respond to a low level on this input by taking the FIQ interrupt exception. This is an asynchronous, level-sensitive input, and must be held low until a suitable response is received from the processor.
nIRQ	IC	Not interrupt request. As nFIQ , but with lower priority. This is an asynchronous, level-sensitive input, and must be held low until a suitable response is received from the processor.
nMCLK	OCZ	Not memory clock output. When SnA is high, nMCLK is the inverse of MCLK . If SnA is low then nMCLK is held low. This output can also be disabled by an MCR instruction to save power if nMCLK is not used.
nMREQ	OCZ	Not memory request. A pipelined signal that changes while MCLK is low to indicate whether or not, in the following cycle, the processor will be accessing external memory. When nMREQ is low, the processor will be accessing external memory.
nPWRSLP	IC	Power Sleep. When low this puts the SA-110 I/O pins into sleep mode. In sleep mode all outputs are driven low except nMREQ which is driven high.
nRESET	IC	Not reset. This is a level sensitive input which is used to start the processor from a known address. A low level will cause the current instruction to terminate abnormally, and the on-chip caches, MMU, and write buffer to be disabled. When nRESET is driven high, the processor will re-start from address 0. nRESET must remain low for at least 2 full MCLK cycles. While nRESET is low the processor will perform idle cycles.
nRESET_OUT	OCZ	Not reset out. This signal is asserted when nRESET is asserted and deasserts when the processor has completed resetting. This signal remains asserted until the PLL is stable.

Table 1: Signal Pin Description

Name	Type	Description
nRW	OCZ	Not read/write. When high this signal indicates a processor write operation; when low, a read. The nRW signal follows address bus timing.
nTRST	IC	Test interface reset. Note this pin does NOT have an internal pullup resistor. This pin must be pulsed or driven low to achieve normal device operation, in addition to the normal device reset (nRESET).
nWAIT	IC	Not wait. When low this allows extra MCLK cycles to be inserted in memory accesses. It must be asserted low before the rising edge of MCLK to extend the MCLK cycle and is latched with the rising edge of MCLK . Note this is different than previous ARM processors that required nWAIT to be asserted for the entire MCLK high time and did not latch nWAIT .
SEQ	OCZ	Sequential address. This signal is the inverse of nMREQ , and is provided for compatibility with existing ARM memory systems. The signal changes while MCLK is high.
SnA	IC	Synchronous/Not Asynchronous. When SnA is low, MCLK is an input and nMCLK is driven low. When SnA is high, nMCLK and MCLK are output clocks with the frequency selected by the MC CFG and CC CFG pins. SnA must remain stable at all times and may not be dynamically changed.
SPDF	IC	SPDF . The SPDF pin should be tied low. It is for DIGITAL use only.
TCK	IC	Test interface reference Clock. This times all the transfers on the JTAG test interface.
TCK_BYP	IC	Test clock PLL bypass. When TCK_BYP is high, the TESTCLK is used as the core clock in place of the PLL clock, when low the internal PLL output is used.
TDI	IC	Test interface data input. Note this pin does NOT have an internal pullup resistor.
TDO	OCZ	Test interface data output. Note this pin does NOT have an internal pullup resistor.
TESTCLK	IC	Test Clock. TESTCLK is used to provide the core clock when TCK_BYP is high. It should be tied low if TCK_BYP is low. This clock should never be driven higher than VDD .
TMS	IC	Test interface mode select. Note this pin does NOT have an internal pullup resistor.
VDD		Positive supply for the core. Eight pins are allocated to VDD .
VDDX		Positive supply for the I/O pins. Nine pins are allocated to VDDX .
VSS		Ground supply. Eighteen pins are allocated to VSS . The ground plane on the board should be the same for these pins.

Notes:

1. When output pads are placed in the high impedance state for long periods, care must be taken to ensure that they do not float to an undefined logic level, as this can dissipate power, especially in the pads.
2. It must be noted that unless all inputs are driven to the **VSS** or **VDDX**, the input circuits will consume power.

Key to Signal Types: **IC** – Input, CMOS threshold
ICOCZ – Input, CMOS threshold, output CMOS levels, tri-stateable
OCZ – Output, CMOS levels, tri-stateable

ARM Implementation Options

3.0 ARM Implementation Options

The following sections describe ARM architecture options that are implemented by the SA-110.

3.1 Big and Little Endian

The big endian bit, in the control register, sets whether the SA-110 treats words in memory as being stored in big endian or little endian format. Memory is viewed as a linear collection of bytes numbered upwards from 0. Bytes 0 to 3 hold the first stored word, bytes 4 to 7 the second and so on.

In the little endian scheme the lowest numbered byte in a word is considered to be the least significant byte of the word and the highest numbered byte is the most significant. Byte 0 of the memory system should be connected to data lines 7 through 0 (**D[7:0]**) in this scheme.

In the big endian scheme the most significant byte of a word is stored at the lowest numbered byte and the least significant byte is stored at the highest numbered byte. Byte 0 of the memory system should therefore be connected to data lines 31 through 24 (**D[31:24]**).

The state of the big endian bit only changes the location of the bytes within a 32-bit word. The accessed bytes are changed for the load byte, store byte, load halfword, and store halfword instructions only. Instruction fetches and word load and stores are not changed by the state of the bigend bit.

3.2 Exceptions

Exceptions arise whenever there is a need for the normal flow of program execution to be broken, so that (for example) the processor can be diverted to handle an interrupt from a peripheral. The processor state just prior to handling the exception must be preserved so that the original program can be resumed when the exception routine has completed. Many exceptions may arise at the same time.

The SA-110 handles exceptions by making use of the banked registers to save state. The old PC and CPSR contents are copied into the appropriate R14 and SPSR and the PC and mode bits in the CPSR bits are forced to a value which depends on the exception. Interrupt disable flags are set where required to prevent otherwise unmanageable nestings of exceptions. In the case of a re-entrant interrupt handler, R14 and the SPSR should be saved onto a stack in main memory before re-enabling the interrupt; when transferring the SPSR register to and from a stack, it is important to transfer the whole 32 bit value, and not just the flag or control fields.

When multiple exceptions arise simultaneously, a fixed priority determines the order in which they are handled. The priorities are listed later in this chapter. Most exceptions are fully defined in the *ARM Architecture Reference*. The following sections specify the exceptions where the SA-110 implementation differs from the *ARM Architecture Reference*.

The SA-110 initiates all exceptions in 32-bit mode. When an exception occurs while the SA-110 is running in 26-bit mode the SA-110 saves only the PC and CPSR. The PC is saved in R14 and the CPSR is saved in the SPSR of the exception mode. The 32-bit handler will have to merge the condition codes, the interrupt enables, and the mode from the SPSR into R14 if a handler wants to run in 26-bit mode.

3.2.1 Reset

When the **nRESET** signal goes low, the SA-110 stops executing instructions, asserts the **nRESET_OUT** pin, and then performs idle cycles on the bus.

When **nRESET** goes high again, the SA-110 does the following:

- (1) Overwrites R14_svc and SPSR_svc by copying the current values of the PC and CPSR into them. The values of the saved PC and CPSR are not defined.
- (2) Forces M[4:0]=10011 (32-bit Supervisor mode) and sets the I and F bits in the CPSR.
- (3) Forces the PC to fetch the next instruction from address 0x0

At the end of the reset sequence, the MMU, Icache, Dcache, and write buffer are disabled. Alignment faults are also disabled, and little endian mode is enabled.

3.2.2 Abort

An abort can be signalled by either the internal memory management unit or from the external **ABORT** input pin. **ABORT** indicates that the current memory access cannot be completed. For instance, in a virtual memory system the data corresponding to the current address may have been moved out of memory onto a disk, and considerable processor activity may be required to recover the data before the access can be performed successfully. The SA-110 checks for **ABORT** during memory access cycles. When aborted the SA-110 will respond in one of two ways:

- (1) If the abort occurred during an instruction prefetch (a *prefetch abort*), the prefetched instruction is marked as invalid but the abort exception does not occur immediately. If the instruction is not executed, for example as a result of a branch being taken while it is in the pipeline, no abort will occur. An abort will take place if the instruction reaches the head of the pipeline and is about to be executed.
- (2) If the abort occurred during a data access (a *data abort*), the action depends on the instruction type.
 - (a) Single data transfer instructions (LDR, STR) will abort with no registers modified.
 - (b) The swap instruction (SWP) is aborted as though it had not executed, though externally the read access may take place.
 - (c) Block data transfer instructions (LDM, STM) abort on the first access that cannot complete. If writeback is set, the base is **NOT** updated. If the instruction would normally have overwritten the base with data (for example, a LDM instruction with the base in the transfer list), the original value in the base register is restored.

When either a prefetch or data abort occurs, the SA-110 performs the following operations:

- (1) Saves the address of the aborted instruction plus 4 (for prefetch aborts) or 8 (for data aborts) in R14_abt; saves CPSR in SPSR_abt.
- (2) Forces M[4:0]=10111 (Abort mode) and sets the I bit in the CPSR.
- (3) Forces the PC to fetch the next instruction from either address 0x0C (prefetch abort) or address 0x10 (data abort).

To return after fixing the reason for the abort, use SUBS PC, R14_abt,#4 (for a prefetch abort) or SUBS PC,R14_abt,#8 (for a data abort). This will restore both the PC and the CPSR and retry the aborted instruction.

ARM Implementation Options

The abort mechanism allows a *demand paged virtual memory system* to be implemented when suitable memory management software is available. The processor is allowed to generate arbitrary addresses, and when the data at an address is unavailable the MMU signals an abort. The processor traps into system software which must work out the cause of the abort, make the requested data available, and retry the aborted instruction. The application program needs no knowledge of the amount of memory available to it, nor is its state in any way affected by the abort.

3.2.3 Vector Summary

Table 2: Vector Summary

Address	Exception	Mode on entry
0x00000000	Reset	Supervisor
0x00000004	Undefined instruction	Undefined
0x00000008	Software interrupt	Supervisor
0x0000000C	Abort (prefetch)	Abort
0x00000010	Abort (data)	Abort
0x00000014	not used	
0x00000018	IRQ	IRQ
0x0000001C	FIQ	FIQ

These are byte addresses, and will normally contain a branch instruction pointing to the relevant routine.

3.2.4 Exception Priorities

When multiple exceptions arise at the same time, a fixed priority system determines the order in which they will be handled:

- (1) Reset (highest priority)
- (2) Data abort
- (3) FIQ
- (4) IRQ
- (5) Prefetch abort
- (6) Undefined Instruction, software interrupt (lowest priority)

Note that not all exceptions can occur at once. Undefined instruction and software interrupt are mutually exclusive since they each correspond to particular (non-overlapping) decodings of the current instruction.

If a data abort occurs at the same time as a FIQ, and FIQs are enabled (that is, the F flag in the CPSR is clear), the SA-110 will enter the data abort handler and then immediately proceed to the FIQ vector. A normal return from FIQ will cause the data abort handler to resume execution. Placing data abort at a higher priority than FIQ is necessary to ensure that the transfer error does not escape detection; the time for this exception entry should be added to worst case FIQ latency calculations.

3.2.5 Interrupt Latencies

Calculating the worst-case interrupt latency for the SA-110 is quite complex (due to the cache, MMU, and write buffer) and is dependent on the configuration of the whole system.

3.3 Coprocessors

The SA-110 has no external coprocessor bus, so it is not possible to add external coprocessors to this device.

SA-110 uses the internal coprocessor designated #15 for control of the on chip MMU, Caches, and clocks. If a coprocessor other than #15 is accessed, then the CPU will take the undefined instruction trap. The coprocessor load, store, and data operation instructions also take the undefined instruction trap.

Instruction Set

4.0 Instruction Set

4.1 Instruction Set

The SA-110 implements the ARM V4 architecture as defined in the *ARM Architecture Reference*, Version A, dated 7 Feb 1996, with previously noted options.

4.2 Instruction Timings

The following table lists the instruction timing for the SA-110. The result delay is the number of cycles the next sequential instruction would stall if it used the result as an input. The issue cycles is the number of cycles this instruction takes to issue. For most instructions the result delay is zero and the issue cycles is one. For load and stores the timing is for cache hits.

Table 3: Instruction Timings

Instruction group	Result delay	Issue Cycles
Data processing shift amount literal	0	1
Data processing shift amount from register	0	2
Mul or Mul/Add giving 32-bit result	1..3	1
Mul or Mul/Add giving 64-bit result	1..3	2
Load Single – writeback of base	0	1
Load Single – load data zero extended	1	1
Load Single -load data sign extended	2	1
Store Single – writeback of base	0	1
Load Multiple (delay for last register)	1	MAX(2, number of registers loaded)
Store Multiple – writeback of base	0	MAX(2, number of registers loaded)
Branch or Branch and Link	0	1
MCR	2	1
MRC	1	1
MSR to control	0	3
MRS	0	1
Swap	2	2

5.0 Configuration

The operation and configuration of the SA-110 is controlled with coprocessor instructions, configuration pins, and with the memory management page tables. The coprocessor instructions manipulate on-chip registers which control the configuration of the cache, write buffer, MMU and a number of other configuration options.

Note: The gray areas in the register and translation diagrams are reserved and should be programmed 0 for future compatibility.

5.1 Internal Coprocessor Instructions

The on-chip registers may be read using MRC instructions and written using MCR instructions. These operations are only allowed in non-user modes and the undefined instruction trap will be taken if accesses are attempted in user mode.

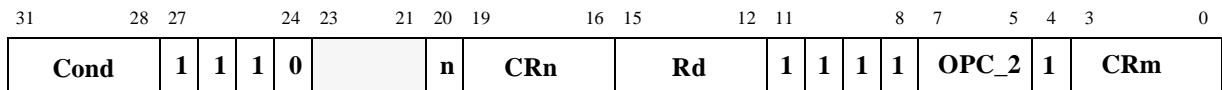

- Cond – ARM condition codes
- CRn – SA-110 Register
- CRm – Function bits for some MRC/MCR instructions
- OPC_2 – Function bits for some MRC/MCR instructions
- Rd – ARM Register
- n – 1 MRC register read
0 MCR register write

Format of Internal Coprocessor Instructions MRC and MCR

Configuration

5.2 Registers

The SA-110 contains registers which control the cache and MMU operation. These registers are accessed using CPRT instructions to coprocessor #15 with the processor in any privileged mode. Only some of registers 0-15 are valid: the result of an access to an invalid register is unpredictable.

Table 4: Cache & MMU Control Registers

Register	Register Reads	Register Writes
0	ID Register	Reserved
1	Control	Control
2	Translation Table Base	Translation Table Base
3	Domain Access Control	Domain Access Control
4	Reserved	Reserved
5	Fault Status	Fault Status
6	Fault Address	Fault Adress
7	Reserved	Cache Operations
8	Reserved	TLB Operations
9..14	Reserved	Reserved
15	Reserved	Test, clock, and Idle

5.2.1 Register 0 – ID

Register 0 is a read-only register that returns the code for this chip: 0x4401A10x. The low order four bits of the register are the chip revision number.

31	24 23	16 15	4 3 0
44	01	A10	Revision

Configuration

5.2.3 Register 2 – Translation Table Base

Register 2 is a read/write register that holds the base of the currently active level one page table. Bits [13:0] are undefined on read, ignored on write.

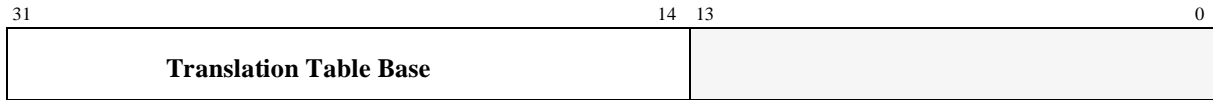

5.2.4 Register 3 – Domain Access Control

Register 3 is a read/write register that holds the current access control for domains 0 to 15.

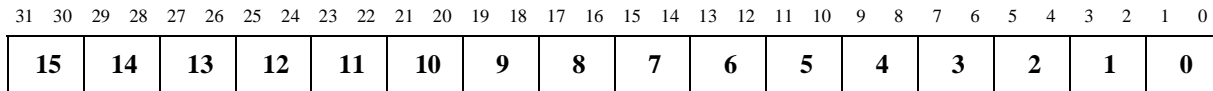

5.2.5 Register 4 – Reserved

Register 4 is reserved. Accessing this register has no effect.

5.2.6 Register 5 – Fault Status

Register 5 is a read/write register. Reading this register returns the current contents of the Fault Status Register (FSR). The FSR is written when a data memory fault occurs or can be written by a MCR to the FSR. It is not updated for a prefetch fault. See Chapter 7.0 Memory Management Unit (MMU) for more details. Bits [31:9] are undefined on read, ignored on write. Bit 8 is ignored on write and is always returned as zero.



5.2.7 Register 6 – Fault Address

Read/Write: Fault Address

Register 6 is a read/write register. Reading this register returns the current contents of the Fault Address Register (FAR). The FAR is written when a data memory fault occurs with the address of the data fault, or can be written by a MCR to the FAR.



5.2.8 Register 7 – Cache Control Operations

Register 7 is a write-only register. The CRm and OPC_2 fields are used to encode the cache control operations. All other values for OPC_2 and CRm are unpredictable.

Table 5: Cache Control Operations

Function	OPC_2	CRm	Data
Flush I+D	0b000	0b0111	Ignored
Flush I	0b000	0b0101	Ignored
Flush D	0b000	0b0110	Ignored
Flush D single entry	0b001	0b0110	Virtual Address
Clean D cache entry	0b001	0b1010	Virtual Address
Drain Write Buffer	0b100	0b1010	Ignored

5.2.9 Register 8 – TLB Operations

Register 8 is a write-only register. The CRm and OPC_2 fields are used to encode the following TLB flush operations. All other values for OPC_2 and CRm are unpredictable.

Table 6: TLB Control Operations

Function	OPC_2	CRm	Data
Flush I+D	0b000	0b0111	Ignored
Flush I	0b000	0b0101	Ignored
Flush D	0b000	0b0110	Ignored
Flush D single entry	0b001	0b0110	Virtual Address

5.2.10 Registers 9 -14 Reserved

The results of accessing any of these registers is unpredictable.

Configuration

5.2.11 Registers 15 – Test, Clock and Idle Control

Register 15 is a write-only register. The CRm and OPC_2 fields are used to encode the following control operations. All other values for OPC_2 and CRm are unpredictable.

Table 7: Test, Clock, and Idle Controls

Function	OPC_2	CRm
Enable odd word loading of Icache LFSR	0b001	0b0001
Enable even word loading of Icache LFSR	0b001	0b0010
Clear Icache LFSR	0b001	0b0100
Move LFSR to R14.Abort	0b001	0b1000
Enable clock switching	0b010	0b0001
Disable clock switching	0b010	0b0010
Disable nMCLK output	0b010	0b0100
Wait for interrupt	0b010	0b1000

5.2.11.1 Icache LFSR Controls

The OPC_2=1 functions are used to control the Icache linear feedback shift register (LFSR) which is used for manufacturing tests.

5.2.11.2 Clock Controls

The four OPC_2=2 functions are used to enable and disable **DCLK** switching, disabling the **nMCLK** output and disabling **MCLK** output and waiting for an interrupt. See Chapter 8.0 SA-110 Clocking for information on their use.

6.0 Caches and Write Buffer

To reduce effective memory access time the SA-110 has an instruction cache, a data cache, and a write buffer. In general these are transparent to program execution. The following sections describe each of these and give all necessary programming information.

6.1 Instruction Cache (Icache)

The SA-110 contains a 16KB instruction cache (Icache). The Icache has 512 lines of 32 bytes (8 words), arranged as a 32-way set-associative cache, and uses the virtual addresses generated by the processor core. The Icache is always reloaded a line at a time (8 words). It may be enabled or disabled via the SA-110 control register and is disabled by the **nRESET** pin. The operation of the cache, when memory management is enabled, is further controlled the *Cacheable* or C bit stored in the memory management page table (see Chapter 7.0 Memory Management Unit (MMU)). If memory management is disabled all addresses are marked as cacheable (C=1). When memory management is enabled the C bit in each page table entry can disable caching for an area of virtual memory.

6.1.1 Icache Operation

In the SA-110 the Icache will be searched regardless of the state of the C bit, only reads that miss the Icache will be affected. If, on an Icache miss, the C bit is a one or the MMU is disabled, a cache line fill of 8 words will be performed and it will be placed in an Icache bank with a round-robin replacement algorithm. If, on a miss, the MMU is enabled and the C bit is a zero for the given virtual address, an external memory access for a single word will be performed and the Icache will not be written. The Icache should be enabled as soon as possible after reset for best performance.

6.1.2 Icache Validity

The Icache operates with virtual addresses, so care must be taken to ensure that its contents remain consistent with the virtual to physical mappings performed by the memory management unit. If the memory mappings are changed, the Icache validity must be ensured. The Icache is not coherent with stores to memory so programs that write cacheable instruction locations must ensure the Icache validity. Instruction fetches do not check the write buffer so data must not only be pushed out of the Icache but the write buffer must also be drained.

6.1.2.1 Software Icache Flush

The entire Icache can be invalidated by writing to the SA-110 cache operations register (Register 7). The cache will be flushed immediately when the register is written, but note that the following four instruction fetches may come from the cache before the register is written.

6.1.3 Icache Enable/Disable and Reset

The Icache is automatically disabled and flushed on **nRESET**. Once enabled, cacheable read accesses will cause lines to be placed in the Icache. If the Icache is subsequently disabled, no new lines will be placed in the Icache, but the Icache will still be searched and if the data is found it will be used by the processor. If the data in the Icache must not be used, then the Icache must be flushed.

6.1.3.1 Enabling the Icache

To enable the Icache set bit 12 in control register. The MMU and Icache may be enabled simultaneously with a single control register write.

Caches and Write Buffer

6.1.3.2 Disabling the Icache

To disable the Icache clear bit 12 in control register.

6.2 Data Cache (Dcache)

The SA-110 contains a 16KB writeback data cache (Dcache). The Dcache has 512 lines of 32 bytes (8 words), arranged as a 32-way set-associative cache, and uses the virtual addresses generated by the processor. A line also contains the physical address the block was fetched from and two dirty bits. There is a dirty bit associated with both the first and second half of the block. When a store hits in the Dcache the dirty bit associated with it is set. When a block is evicted from the Dcache the dirty bits are used to decide if all, half, or none of the block will be written back to memory using the physical address stored with the block. The Dcache is always reloaded a line at a time (8 words). It may be enabled or disabled via the SA-110 control register and is disabled on **nRESET**. The operation of the Dcache is further controlled by the *Cacheable* or C bit and the *Bufferable* or B bit stored in the memory management page table (see Chapter 7.0 Memory Management Unit (MMU)). For this reason, in order to use the Dcache, the MMU must be enabled. The two functions may however be enabled simultaneously, with a single write to the control register.

6.2.1 Cacheable Bit – C

The cacheable bit determines whether data being read may be placed in the Dcache and used for subsequent read operations. Typically main memory will be marked as cacheable to improve system performance, and I/O space as noncacheable to stop the data being stored in SA-110's Dcache. [For example if the processor is polling a hardware flag in I/O space, it is important that the processor is forced to read data from the external peripheral, and not a copy of initial data held in the cache].

6.2.2 Bufferable Bit - B

The bufferable bit does not affect writes that hit in the Dcache. If a store hits in the Dcache the store is assumed to be bufferable. Writebacks of dirty lines are treated as bufferable writes. See section 6.3 on page 22 for more information on the B bit.

6.2.3 Dcache Operation

In the SA-110 the Dcache will be searched regardless of the state of the C bit, only reads that miss the Dcache will check the C bit. The C bit controls loading the Dcache on a miss not checking the Dcache on an access.

6.2.3.1 Cacheable Reads C = 1

A cache line fill of 8 words will be performed and it will be placed in a Dcache bank with a round-robin replacement algorithm.

6.2.3.2 Noncacheable Reads C = 0

An external memory access will be performed and the Dcache will not be written.

Note: Load Multiples to C=0 space do NOT perform a burst read.

6.2.4 Dcache Validity

The Dcache operates with virtual addresses, so care must be taken to ensure that its contents remain consistent with the virtual to physical mappings performed by the memory management unit. If the memory mappings are changed, the Dcache validity must be ensured.

6.2.4.1 Software Dcache Flush

SA-110 supports the flush and clean operations on single entries of the Dcache by writes to the cache operations registers. The flush whole cache is also supported. Note that since this is a writeback cache, in order to not lose data, a flush whole must be preceded by a sequence of loads to cause the cache to write back any dirty entries. The following code will cause the Dcache to flush all dirty entries.

```
;+
;Call:
;   R0 points to the start of a 16384-byte region of readable data used
;   only for this cache flushing routine. If this area is used for
;   by other code then 32K must be loaded and the flush MCR is not
;   not needed.
;   bl writeBackDcache
;Return:
;   R0, R1, R2 trashed
;   Data cache is clean
;-
writeBackDcache
    add    r1, r0, #16384
ll
    ldr    r2, [r0], #32
    teq    r1, r0
    bne    ll
    mcr    p15, 0, r0, c7, c6, 0
    mov    pc, r14
```

6.2.4.2 Doubly Mapped Space

Since the cache works with virtual addresses, it is assumed that every virtual address maps to a different physical address. If the same physical location is accessed by more than one virtual address, the cache cannot maintain consistency, since each virtual address will have a separate entry in the cache, and only one entry will be updated on a processor write operation. To avoid any cache inconsistencies, doubly-mapped virtual addresses should be marked as noncacheable.

6.2.5 Dcache Enable/Disable and Reset

The Dcache is automatically disabled and flushed on **nRESET**. Once enabled, cacheable read accesses will cause lines to be placed in the cache. If subsequently disabled, no new lines will be placed in the cache, but it will still be searched and if the data is found it will be used by the processor. Write operations will continue to update the cache, thus maintaining consistency with the external memory. If the data in the cache must not be used, then the cache must be flushed.

Caches and Write Buffer

6.2.5.1 Enabling the Dcache

To enable the Dcache, make sure that the MMU is enabled first by setting bit 0 in Control Register, then enable the Dcache by setting bit 2 in Control Register. The MMU and Dcache may be enabled simultaneously with a single control register write.

6.2.5.2 Disabling the Dcache

To disable the Dcache clear bit 2 in Control Register.

6.3 Write Buffer (WB)

The SA-110 write buffer is provided to improve system performance. It can buffer up to eight blocks of data of 1 to 16 bytes, at independent addresses. It may be enabled or disabled via the W bit (bit 3) in the SA-110 control register and the buffer is disabled and all entries are marked empty on reset. The operation of the write buffer is further controlled by the *Cacheable* or C bit and the *Bufferable* or B bit, which are stored in the memory management page tables. For this reason, in order to use the write buffer, the MMU must be enabled. The two functions may however be enabled simultaneously, with a single write to the control register. For a write to use the write buffer, both the W bit in the control register, and the B bit in the corresponding page table must be set. It is not possible to abort buffered writes externally; the abort pin will be ignored.

6.3.1 Bufferable Bit

This bit controls whether a write operation may use the write buffer. Typically main memory will be bufferable and I/O space unbufferable.

6.3.2 Write Buffer Operation

When the CPU performs a store, the Dcache is first checked. If the Dcache hits on the store and the protection for the location and mode of the store allows the write then the write completes in the cache and the writebuffer is not used. If the location misses in the Dcache then the translation entry for that address is inspected and the state of the B and C bits determines which of the three following actions are performed. If the write buffer is disabled via the SA-110 Control Register, writes are treated as if the B bit is a zero.

6.3.2.1 Writes to a Bufferable and Cacheable Location (B=1,C=1)

If the write buffer is enabled and the CONFIG pin is asserted and the processor performs a write to a bufferable and cacheable location, and the data is in the Dcache, then the data is written to the Dcache, and the Dcache line is marked dirty. If a write to a bufferable area misses in the data cache, the data is placed in the write buffer and the CPU continues execution. When placing the write data into the write buffer if the data is being written to the same 16 byte aligned area of the previous write then the current write is merged into the same entry in the write buffer. The write buffer performs the external write some time later. If a write is done and the write buffer is full then the processor is stalled until there is sufficient space in the buffer. If the CONFIG pin is not asserted then no merging is allowed.

6.3.2.2 Writes to Bufferable and Noncacheable Location (B=1,C=0)

If the write buffer is enabled and the processor performs a write to a bufferable but noncacheable location, and misses in the data cache, the data is placed in the write buffer and the CPU continues execution. When placing the write data into the write buffer no merging is allowed and each write takes its own write buffer entry. The write buffer performs the external write some time later.

Note: the case of a data cache hit for a bufferable but noncacheable location is a system programming bug. In this case the data is written to the Dcache, and the Dcache line is marked dirty.

6.3.2.3 Unbufferable Writes (B=0)

If the write buffer is disabled or the CPU performs a write to an unbufferable area, the processor is stalled until the write buffer empties and the write completes externally. This will require several external clock cycles.

6.3.3 Enabling the Write Buffer

To enable the write buffer, ensure the MMU is enabled by setting bit 0 in control register, then enable the write buffer by setting bit 3 in control register. The MMU and write buffer may be enabled simultaneously with a single write to the control register.

6.3.4 Disabling the Write Buffer

To disable the write buffer, clear bit 3 in control register. Note that any writes already in the write buffer will complete normally, but a drain write buffer needs to be done to force all writes out to memory.

Note the write buffer will be used for copybacks from the Dcache even when it is disabled.

Memory Management Unit (MMU)

7.0 Memory Management Unit (MMU)

7.1 Overview

The SA-110 implements the standard ARM memory management functions using two, 32-entry fully associative TLBs. One is used for instruction accesses and the other for data accesses. On a TLB miss the translation table hardware is invoked to retrieve the translation and access permission information. Once retrieved, if the entry maps to a valid page or section then the information is placed into the TLB. The replacement algorithm in the TLB is round robin. For an invalid page or section an abort is generated and the entry is not placed in the TLB.

7.1.1 MMU Registers

See section 5.2 on page 14 for a description of the MMU CP15 registers supported by the SA-110.

7.2 MMU Faults and CPU Aborts

The MMU generates four faults:

- Alignment Fault
- Translation Fault
- Domain Fault
- Permission Fault

Alignment faults are generated by word loads or stores with the low order two address bits not zero, and by load or store halfwords with the low order address bit a one. Translation faults are generated by access to pages marked invalid by the memory management page tables. Domain faults and permission faults are generated by accesses to memory disallowed by the current mode, domain, and page protection. See *ARM Architecture Reference* for more information.

In addition, an external abort may be raised on external data accesses.

7.3 External Aborts

In addition to the MMU-generated aborts, SA-110 has an external abort pin which may be used to flag an error on an external memory access. However, some accesses aborted in this way are not restartable not all accesses can be aborted in this way, so this pin must be used with great care. Writes to memory areas marked as bufferable ignore the external abort pin.

The following accesses may be aborted and restarted safely. If any of the following are aborted the external access will cease on the next cycle. In the case of a read-lock-write sequence in which the read aborts, the write will not happen.

- Reads
- Unbuffered writes
- Level One descriptor fetch
- Level Two descriptor fetch
- Read-lock-write sequence

Memory Management Unit (MMU)

7.3.1 Cacheable Reads (Cache Line Fills)

A cache line fill may be safely aborted on any word in the transfer. If an abort occurs during the cache line fill then the cache will be purged, so it will not contain invalid data. If the abort happens before the word that was requested by the access is returned, the load will be aborted. If the abort happens after the word that was requested by the access is returned, the load will complete, and the fill will be aborted (but no exception will be generated).

7.3.2 Buffered Writes

Buffered writes cannot be externally aborted. Therefore, the system should be configured such that it does not do buffered writes to areas of memory which are capable of flagging an external abort.

7.4 Interaction of the MMU, Icache, Dcache and Write Buffer

The MMU, Icache, Dcache, and WB may be enabled/disabled independently. The Icache can be enabled with the MMU enabled or disabled. However, the Dcache and WB can only be enabled when the MMU is enabled. Because the write buffer is used to hold dirty copyback cached lines from the Dcache, it must be enabled along with the Dcache. Therefore only four of the eight combinations of the MMU, Dcache, and WB enables are valid. There are no hardware interlocks on these restrictions, so invalid combinations will cause undefined results.

Table 8: Valid MMU, Dcache & Write Buffer Combinations

MMU	Dcache	WB
Off	Off	Off
On	Off	Off
On	Off	On
On	On	On

The following procedures must be observed.

To enable the MMU:

- (1) Program the translation table base and domain access control registers
- (2) Program level 1 and level 2 page tables as required
- (3) Enable the MMU by setting bit 0 in the control register.

Note:

Care must be taken if the translated address differs from the untranslated address as the three instructions following the enabling of the MMU may have been fetched using “flat translation” and enabling the MMU may be considered as a branch with delayed execution. A similar situation occurs when the MMU is disabled. Consider the following code sequence:

Memory Management Unit (MMU)

```
MOV          R1, #0x1
MCR          15,0,R1,0,0          ; Enable MMU
Fetch Flat
Fetch Flat
Fetch Flat
Fetch Translated
```

To disable the MMU

- (1) Disable the WB by clearing bit 3 in the control register.
- (2) Disable the Dcache by clearing bit 2 in the control register.
- (3) Disable the Icache by clearing bit 12 in the control register.
- (4) Disable the MMU by clearing bit 0 in the control register.

Note:

If the MMU is enabled, then disabled and subsequently re-enabled the contents of the TLB will have been preserved. If these are now invalid, the TLB should be flushed before re-enabling the MMU.

Disabling of all three functions may be done simultaneously.

8.0 SA-110 Clocking

8.1 SA-110 Operating Modes

The SA-110 supports three operating modes, normal, idle, and sleep. The SA-110 can be switched between the three operating modes to minimize power consumption. In normal mode the chip executes instructions. In idle mode no instructions are executed but the internal phase-locked loop (PLL) continues to run. In sleep mode the core power (**VDD**) is switched off; the chip does not execute instructions, and the PLL does not run. The I/O power, **VDDX**, is used to hold the all output pins that are enabled at a low state except **nMREQ** which is held at a high state.

8.2 SA-110 Clocking

The SA-110 receives a 3.57/3.68-MHz clock (**CLK**) from a crystal-based clock generator on the **CLK** pin and uses an internal PLL to lock to the input clock and multiply the frequency by a variable multiplier to produce a high-speed core clock (**CCLK**). The 3.57/3.68-MHz oscillator and PLL run constantly in normal and idle modes. There are two clocking domains in SA-110; the core logic domain clocked by **DCLK** and the bus interface domain clocked by **MCLK**. The core clock, **DCLK**, switches between being driven by the high-speed core clock, **CCLK** and the bus clock, **MCLK**. **CCLK** is used except when SA-110 is waiting for fills to complete after a cache miss.

At RESET, clock switching is disabled and the **DCLK** is driven from **MCLK**. The time from the deassertion of the **nRESET** (and the **nPWRSLP**) pin until the chip comes out of reset (and **nRESET_OUT** deasserts) is about 150 μ secs and is asynchronous (to **MCLK**). The clock switching can also be disabled by writing to the CP15 register 15 with OPC_2=2 and CRm=2. Clock switching is enabled by writing to the CP15 register 15 with OPC_2=2 and CRm=1. Disabling switching only disables switching for **DCLK**, it does not force the **DCLK** to **MCLK**. To force **DCLK** to be driven by **MCLK** after disabling switching, force an instruction or data cache miss.

The SA-110 can be configured to either source or sink the **MCLK** pin. If **SnA** is deasserted, **MCLK** is an input to the SA-110. If **SnA** is asserted the SA-110 drives the **MCLK** pin with clock generated by dividing **CCLK** by 2 to 9 as specified by the **MCCFG** pins. The SA-110 synchronizes signals which cross between the **CCLK** and **MCLK** domains. The **SnA** pin should be programmed by connecting it to **VDDX** or **VSS** and should not change. With **SnA** asserted **nMCLK**, an inverted copy of **MCLK** is also provided. It is enabled at reset and can be disabled by writing to the CP15 register 15 with OPC_2=2 and CRm=4 to save power if it is not used. If **SnA** is a 1 then **MCLK** and **nMCLK** start clocking about 10 μ secs before the **nRESET_OUT** deasserts. If **SnA** is deasserted the **nMCLK** pin is held high. The only difference between running with **SnA** asserted or deasserted is that **MCLK** is driven into or out of the SA-110. The **SnA** mode is intended to provide a low-cost system clock. For the highest performance systems an external clock generator may be a better choice.

8.2.1 Switching to Idle Mode

With **SnA** deasserted, idle mode is entered by disabling clock switching and then doing a load from a noncacheable location (C=0). The external driver of **MCLK** should then stop **MCLK** to stop the SA-110 from executing instructions. To resume normal operation **MCLK** is restarted and clock switching is enabled.

With **SnA** asserted, idle mode is entered by disabling clock switching, then doing a load from a noncacheable location (C=0), and then doing a wait for interrupt instruction. The SA-110 stops driving **MCLK** when it is low and holds **MCLK** low. Asserting either **nFIQ** or **nIRQ** will cause **MCLK** to start clocking again. To resume normal operation, reenable clock switching.

SA-110 Clocking

8.2.2 Switching to Sleep Mode

To enter sleep mode first assert **nRESET** for at least 20 ns and then assert **nPWRSLP**, then switch off the **VDD** power (drive **VDD** to 0 volts). To exit sleep mode restore the **VDD** supply and deassert **nRESET** and **nPWRSLP**. The order of deassertion of **nRESET** and **nPWRSLP** does not matter. Note there is no difference between initial reset and leaving sleep mode.

8.2.3 Core Clock Configuration - CCCFG

The high speed core clock frequency is configured at reset by the four core clock configuration pins (**CCCFG[3:0]**). These pins should be programmed by connecting them to **VDDX** or **VSS** and should not change .

Table 9: CCLK Configurations

CCCFG	CCLK Frequency in MHz (3.57 MHz Input)	CCLK Frequency in MHz (3.68 MHz Input)
0	85.7	88.3
1	92.7	95.6
2	96.4	99.4
3	103.5	106.7
4	139.2	143.5
5	146.4	150.9
6	157.1	161.9
7	164.2	169.3
8	185.6	191.3
9	196.3	202.4
10	207.0	213.4
11	221.3	228.1
12	235.5	242.8
13	249.9	257.6
14	267.8	276.0
15	278.4	287.0

8.2.4 Memory Clock Configuration - MCCFG

If **SnA** is asserted then the **MCLK** frequency is selected by the three memory clock configuration pins (**MCCFG[2:0]**). These pins should be programmed by connecting them to **VDDX** or **VSS** and should not change. The following table gives the **MCLK** divisors as a function of the **MCCFG** pins. With **SnA** asserted, **MCLK** is a 50% duty cycle clock. The nominal frequency is the **CCLK** frequency divided by the selected divisor. With **SnA** asserted, the low and high period of **MCLK** is generated at $\pm 5\%$ of the nominal frequency short term and at the error of the crystal oscillator long term.

Note: Some combinations of **MCCFG** and **CCCFG** settings will produce an **MCLK** output that exceeds the maximum supported **MCLK** frequency.

Note: For pass one parts, an odd divisor n with a **CCLK** cycle time of T_{cycle} will produce an **MCLK** with a high time of $T_{cycle} * (n-1)/2$ and a low time of $T_{cycle} * (n+2)/2$.

Table 10: MCLK Configurations

MCCFG	CCLK divisor
0	2
1	3
2	4
3	5
4	6
5	7
6	8
7	9

8.2.5 Tester and Debug Clocks

If **TCK_BYP** is high then the PLL output is not used and the high speed core clock is supplied externally on the **TESTCLK** pin. This mode is for testing use only and not supported for standard operation. There are important restrictions on use of **TESTCLK** which must be observed to avoid permanent damage to the chip. Casual use of **TESTCLK** is strongly discouraged.

Bus Interface

9.0 Bus Interface

The following chapter describes the external bus interface for SA-110.

9.1 Bus Modes

The SA-110 bus has two modes, standard and enhanced. When in enhanced mode data cache line fills are wrapped to provide the critical word first, and the write buffer allows more generalized merging. The **CONFIG** signal is asserted (=1) for enhanced mode and deasserted (=0) for standard mode. The **CONFIG** signal can only change while **nRESET** is asserted.

9.1.1 Standard and Enhanced Mode

In enhanced mode line fills are performed with the critical word first. The burst read is wrapped at the end of the 4-word cache subblock, then the other subblock is accessed in the same order. In standard mode, line fills are started on cache block word 0 so no wrap is needed. The byte mask is presented on the **A[1:0]** and **MAS[1:0]** pins and the byte mask bits are asserted low on reads to indicate the required data.

Note: This matches current SSRAMs, burst mode EDO DRAMs, and SDRAMs.

Table 11: Enhanced Mode Wrapping Order

Miss Address Bits [4:2]	Fill Order
0	0,1,2,3,4,5,6,7
1	1,2,3,0,5,6,7,4
2	2,3,0,1,6,7,4,5
3	3,0,1,2,7,4,5,6
4	4,5,6,7,0,1,2,3
5	5,6,7,4,1,2,3,0
6	6,7,4,5,2,3,0,1
7	7,4,5,6,3,0,1,2

In enhanced mode, the write buffer is allowed to merge random byte, halfword, and word stores. On each bus cycle the word address is specified on the **A[31:2]** pins and the bytes to be read/written are specified by a byte mask. The byte mask bits [3:0] specify that bytes [3:0] of the data bus are being transferred. The byte mask is presented on the **A[1:0]** and **MAS[1:0]** pins and is asserted low.

Table 12: Byte Mask

Byte Mask Pins	Dbus Bytes
A[1]	D[31:24]
A[0]	D[23:16]
MAS[1]	D[15:8]
MAS[0]	D[7:0]

In standard mode the write buffer will only merge stores from store multiple instructions and castouts. In standard mode a **MAS[1:0]** of 2 is for word, 1 is for halfword, 0 is for byte. The full byte address of the transfer is given by **A[31:0]**

Read data must always be returned on the correct byte of the data bus **D[31:0]**. The chip provides write data on the data bus bytes specified by the byte mask in Enhanced mode or by the low order two address bits and the memory access size in Standard mode.

Note: Unlike previous ARM chips the SA-110 does not replicate byte stores to all four bytes of the data bus.

9.2 SA-110 Bus Stalls

The bus interface is controlled by **MCLK**, and all timing parameters are referenced with respect to this clock. The way the bus is stalled depends on the mode of the bus. If the system is providing **MCLK** (**SnA=0**), the bus is stalled in one of two ways.

- 1) The low or high phases of the clock may be stretched
- 2) **nWAIT** can be used to insert entire **MCLK** cycles into the access. When low, this signal maintains the low phase of the cycle by gating out **MCLK** internally. The signal **nWAIT** is asserted before the rising edge of **MCLK** and latch by the SA-110.

If the SA-110 is providing **MCLK** (**SnA=1**), only the **nWAIT** signal can be used to stall the bus with the same timing as with **SnA=0**.

The **ABORT** input is not sampled during clock cycles where **nWAIT** is stalling the bus.

Bus Interface

9.3 Cycle Types

There are two cycle types performed by the SA-110. These are *idle* cycles and *sequential* cycles. Idle and sequential cycles are combined to perform memory accesses. The two cycle types are differentiated by **nMREQ**. The **SEQ** signal is the inverse of **nMREQ** and is provided for compatibility with earlier memory controllers. **nMREQ** and **SEQ** are pipelined, and so their value determines what type the following cycle will be **nMREQ** and **SEQ** become valid during the low phase of the cycle before the one to which they refer. The following table shows the encoding used to generate the idle and sequential cycles.

Table 13: Cycle Type Encodings

nMREQ	Cycle Type
0	Sequential
1	Idle

The address from the SA-110 becomes valid during the high phase of **MCLK**, but can be delayed by using **APE**. It is also pipelined, and its value refers to the following memory access.

9.4 Memory Access

There are two types of memory access. These are *non-sequential* and *sequential*. The non-sequential cycles occur when a new memory access takes place. Sequential cycles occur when the cycle is of the same type as, and the address is 1 word (4 bytes) greater than, the previous access or during cache line fills. Cache line fill cycles occur in response to a cache miss and the address sequence is given above. Burst reads are only done for cache line fills. Burst writes are done for castouts of dirty data and data stores that have merged in the write buffer. Cache line fills have the **CLF** high and use the defined wrapping order but otherwise are the same as sequential cycles. **CLF** has the same timing as the address.

Non-sequential accesses consist of an idle cycle followed by a sequential cycle, sequential accesses consist simply of a sequential cycle.

9.5 Read/Write

Memory accesses may be read or write, differentiated by the signal **nRW**. This signal has the same timing as the address. In the case of a write, the SA-110 outputs data on the data bus during the memory cycle. They become valid during **MCLK** low, and are held until the end of the cycle. In the case of a read, the data is sampled at the end of the memory cycle. **nRW** may not change during a sequential or cache line fill access, so if a read from address A is followed immediately by a write to address (A+4), then the write to address (A+4) would be a non-sequential access.

9.6 Address Pipeline Enable (APE)

APE is used to control the timing of the address signals including **A[31:0]**, **MAS[1:0]**, **nRW**, **CLF**, and **LOCK**. Normally these signals change during **MCLK** high, but they may be held to the next **MCLK** low if **APE** is low. **APE** is a static configuration pin and must remain stable at all times. The rest of this chapter assumes **APE** is high. If **APE** is low the address will be held a **MCLK** phase longer and be driven an **MCLK** phase later.

9.7 Memory Access Types

The following timing diagrams assume **APE** is high and are only included to demonstrate timing relationships. Figure 3 shows a 1-word read or write memory access. Figure 4 shows a 2-word sequential access. Figure 5 shows two 1-word accesses back-to-back. Notice that an idle cycle followed by a sequential cycle distinguishes a nonsequential access.

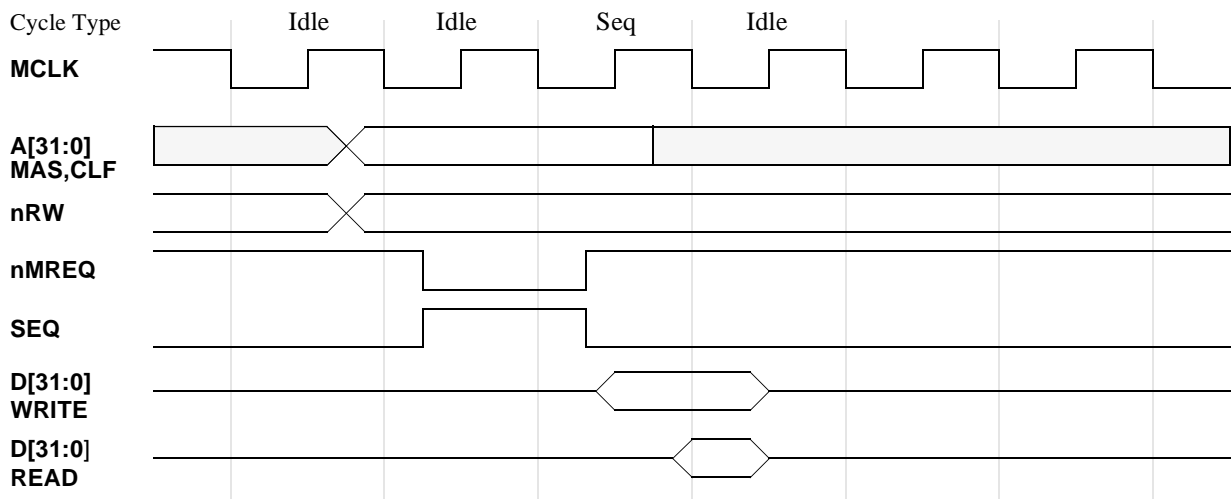

Figure 3: Read or Write (One Word)

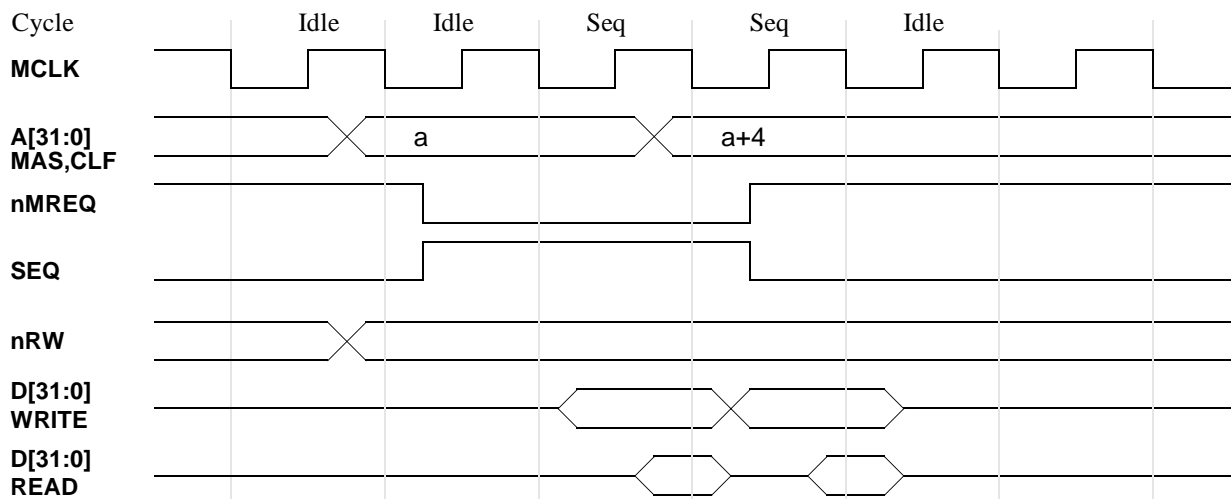

Figure 4: Sequential Read or Write (Two Word)

Bus Interface

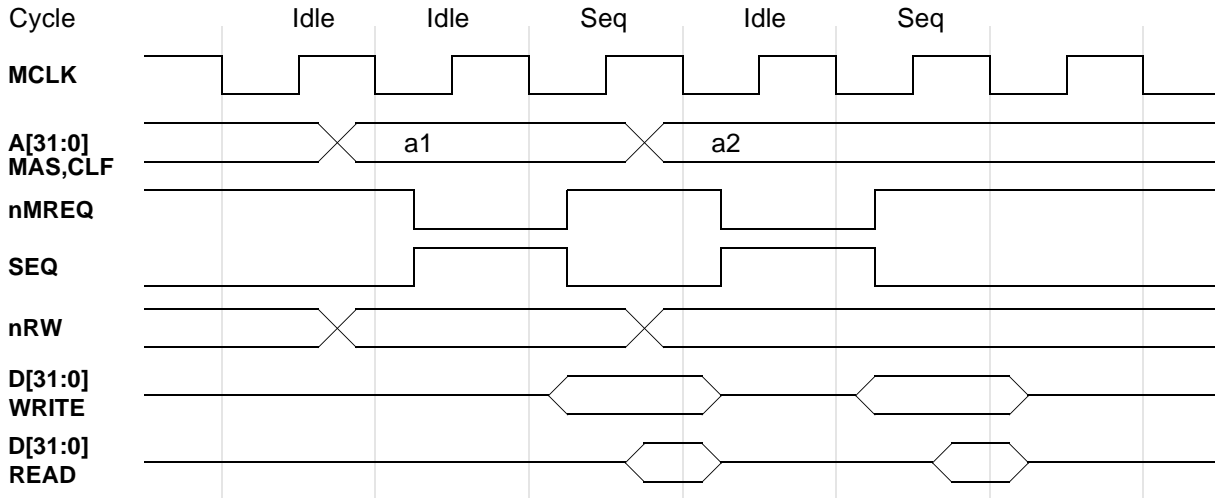

Figure 5: Two 1-Word Nonsequential Reads or Writes Back-to-Back

Note that the data bus is piped one cycle after the address bus. This means that for a read following a write, the data bus is not tristated by the processor until the falling edge of **MCLK** in the **SEQ** cycle of the **READ**. Notice that the asserting **nWAIT** will extend the time the processor is driving the data bus.

9.8 External Accesses

The SA-110 performs bus access for many different operations. All are constructed by combinations of non-sequential or sequential accesses. There may be any number of idle cycles between two other memory accesses. If a memory access is followed by an idle period on the bus (as opposed to another non-sequential access), then the address **A[31:0]**, and the signals **nRW** and **DL[1:0]** will remain at their previous value in order to avoid unnecessary bus transitions.

The accesses performed by a SA-110 are:

Unbuffered Write	Level 1 translation fetch
Uncached Read	Level 2 translation fetch
Buffered Write	Cache Line Copyback
Cache line fill	Read-Lock-Write sequence

9.8.1 Unbuffered Writes / Noncacheable Reads

Unbuffered writes and noncacheable reads are the most basic access types. Each may consist of a single access. The cycles always reflect the type (read or write) of the instruction requesting the cycle. Level 1 and 2 translation fetches also generate noncacheable reads.

9.9 Buffered Write

Buffered writes can consist of sequential or nonsequential accesses. Note, if in enhanced mode, that if several write accesses are stored concurrently within the write buffer, then each access on the bus will start with a nonsequential access. If several write accesses occur to the same cache subblock, the SA-110 will merge these in the write buffer and write to memory using several sequential accesses with the byte masks indicating the valid byte lanes. Burst writes are done for castouts of dirty data and data stores that have merged in the write buffer. Cache line copybacks are also buffered writes.

9.10 Cache Line Fill

This access appears on the bus as a nonsequential access followed by sequential accesses. Cache line fills are not required to start on an 8-word boundary and will be 8 words long. The first access will fetch the critical word if the bus is in enhanced mode or word 0 if in standard mode. CLF will be high for line fetches. The following diagram is a cache line fill in enhanced mode. If it was in standard mode the fill would have started at location 0x00 rather than location 0x18.

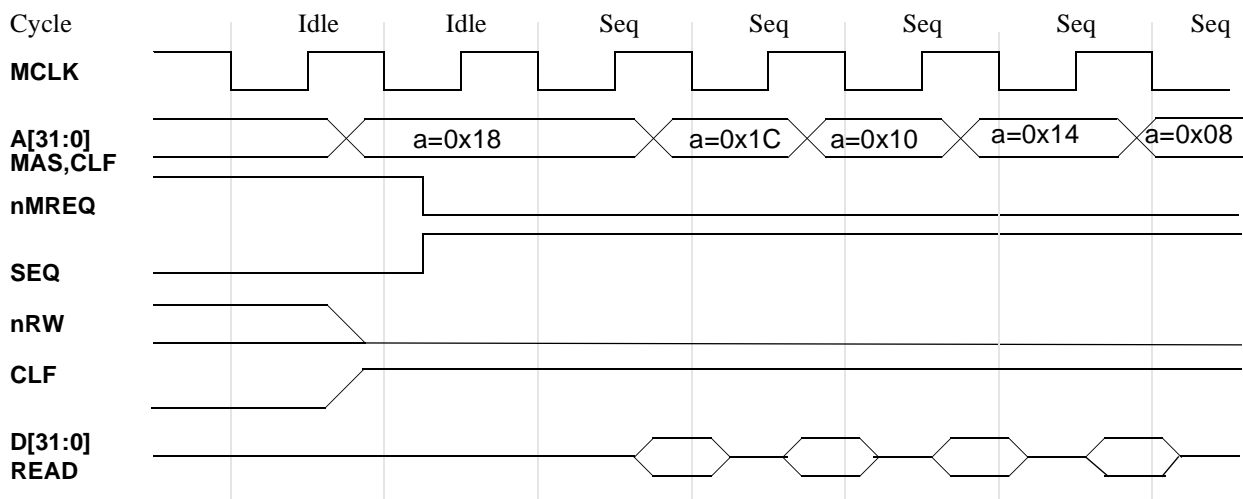

Figure 6: Cache Line Fill

9.11 Read-Lock-Write

The read-lock-write sequence is generated by an SWP instruction to a noncacheable/nonbufferable location. On the bus it consists of a single word read access followed by a single word write access to the same address, and both are treated as non-sequential accesses. The cycle is differentiated by the **LOCK** signal. **LOCK** has the timing of address, ie it goes high in the high phase of **MCLK** at the start of the read access. However, it always goes low at the end of the write access, even if the following cycle is an idle cycle (unless of course the following access was a read-lock-write sequence). There may be several idle cycles between the read and the write. Note that for a cacheable/bufferable access the two access are done in the data cache, preceded by a cache line fill if needed.

Bus Interface

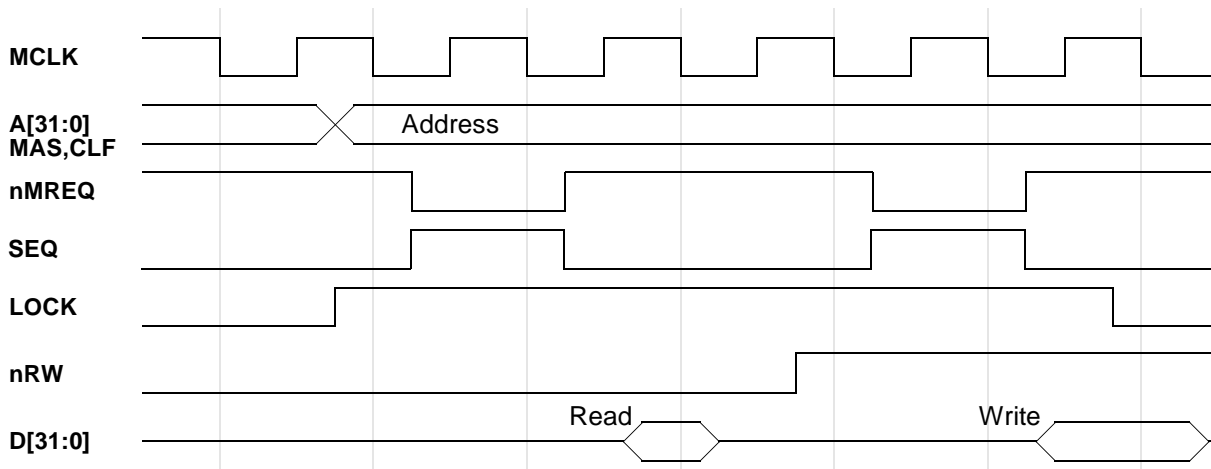

Figure 7: Read-Lock-Write

9.12 Stalling the Bus

The SA-110 can be stalled by **nWAIT**, as shown for a load in Figure 8. The following diagram shows part of a load request that has been stalled for one cycle waiting for return data on the third word.

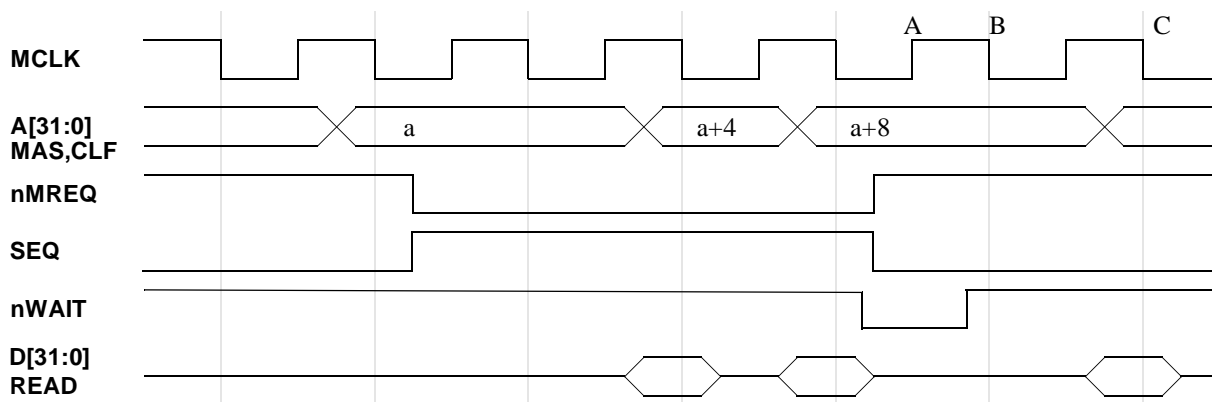

Figure 8: Using **nWAIT** to Stop the SA-110 for One MCLK Cycle

The SA-110 samples the **nWAIT** signal pin at time A. The signal **nWAIT** must meet setup and hold requirements with respect to the rising edge of **MCLK** at A. Without the stall cycle, the data would have been sampled at time B. Inserting a single stall cycle causes the data to be sampled at time C.

9.13 Summary of Transactions

The SA-110 will only generate a subset of all possible transactions on the bus. The SA-110 will generate only single nonsequential transactions and bursts described in the following sections.

9.13.1 Read Bursts

The only actions that cause read bursts are cache line fills. All other reads will be single nonsequential accesses. All cache line fills are 8 words long.

9.13.2 Write Bursts

In standard mode write bursts are caused by STM to B=1 locations and castouts of the data cache. Because the data cache keeps a dirty bit for each 16-byte subblock in standard mode, write bursts are either 4 or 8 words long. In enhanced mode, the write buffer will merge random writes. The write burst sizes in enhanced mode are 2, 3, 4, or 8 words. The **CLF** bit is set on stores. The **CLF** signal is asserted on stores for all 32-byte write bursts. Note that pass one parts never assert **CLF** on writes. When **CLF** is asserted, the external memory system does not need to wait until the byte mask information is valid during write bursts. Optimization is aided because all byte lanes will be valid.

9.13.3 Transaction Summary

The following table lists all the transactions that the SA-110 can generate. No burst will cross an aligned 32-byte boundary.

Table 14: SA-110 Transactions

Bus Operation	CONFIG	Burst Size	Starting Address Bits [4:2]	Note
Read single	0 or 1	1	Any	
Read burst	0	8	0	Generated by cache line fills. CLF is asserted.
Read burst	1	8	Any	Generated by cache line fills. CLF is asserted.
Write single	0	1	Any	
Write single	1	1	Any	1..4 bytes are written as specified by the byte mask.
Write burst	0	2	0, 1, 2 4, 5, 6	All 8 bytes are written.
Write burst	0	3	0, 1 4, 5	All 12 bytes are written.

Bus Interface

Table 14: SA-110 Transactions

Write burst	0	4	0 4	All 16 bytes are written
Write burst	1	2	0, 1, 2 4, 5, 6	Each word can have one to four bytes written
Write burst	1	3	0, 1 4, 5	The first and last word can have one to four bytes written. The middle word can have zero to four bytes written
Write burst	1	4	0 4	The first and last word can have one to four bytes written. The middle words can have zero to four bytes written
Write burst	0 or 1	8	0	CLF is asserted and all 32 bytes are written

10.0 Boundary Scan Test Interface

The boundary-scan interface conforms to the IEEE Std. 1149.1 – 1990, *Standard Test Access Port and Boundary-Scan Architecture* (please refer to this standard for an explanation of the terms used in this section and for a description of the TAP controller states.) The SA-110 only supports JTAG continuity testing.

10.1 Overview

The boundary-scan interface provides a means of driving and sampling all the external pins of the device irrespective of the core state. This function permits testing of both the device's electrical connections to the circuit board, and (in conjunction with other devices on the circuit board having a similar interface) testing the integrity of the circuit board connections between devices. The interface intercepts all external connections within the device, and each such *cell* is then connected together to form a serial register (the boundary scan register). The whole interface is controlled via five dedicated pins: **TDI**, **TMS**, **TCK**, **nTRST** and **TDO**. Figure 9: Test Access Port (TAP) Controller State Transitions shows the state transitions that occur in the TAP controller.

Boundary Scan Test Interface

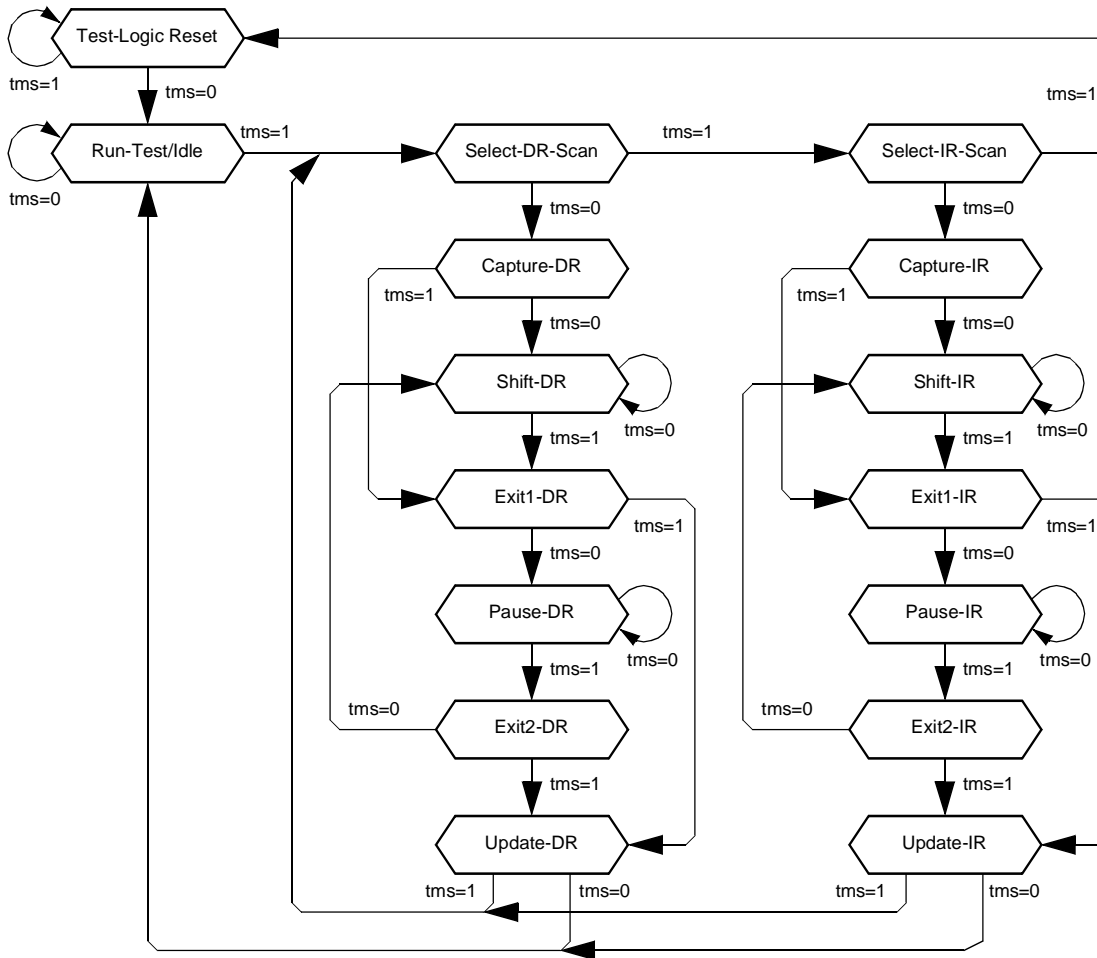

Figure 9: Test Access Port (TAP) Controller State Transitions

10.2 Reset

The boundary-scan interface includes a state-machine controller (the TAP controller). In order to force the TAP controller into the correct state after power-up of the device, a reset pulse must be applied to the **nTRST** pin. If the boundary scan interface is to be used, then **nTRST** must be driven low, and then high again. If the boundary scan interface is not to be used, then the **nTRST** pin may be tied permanently low. Note that a clock on **TCK** is not necessary to reset the device.

The action of reset (either a pulse or a DC level) is as follows:

System mode is selected (the boundary scan chain does NOT intercept any of the signals passing between the pads and the core).

IDcode mode is selected. If **TCK** is pulsed, the contents of the ID register will be clocked out of **TDO**.

10.3 Pullup Resistors

The IEEE 1149.1 standard effectively requires that **TDI**, **nTRST** and **TMS** should have internal pullup resistors. In order to minimise static current draw, **nTRST** has an internal pulldown resistor. These four pins can be left unconnected for normal operation and overdriven to use the JTAG features.

10.4 nPWRSLP

The **nPWRSLP** input pin is not sampled by the JTAG interface and must be deasserted to use the JTAG interface. The **TDO** pin is tristated when **nPWRSLP** is asserted.

10.5 Instruction Register

The instruction register is 5 bits in length.

There is no parity bit. The fixed value loaded into the instruction register during the CAPTURE-IR controller state is: 00001.

10.6 Public Instructions

The following public instructions are supported:

Instruction	Binary Code
EXTEST	00000
SAMPLE/PRELOAD	00001
CLAMP	00100
HIGHZ	00101
IDCODE	00110
BYPASS	11111
Private	00010, 00011, 00111, 01000-01111, 10000-11110

In the descriptions that follow, **TDI** and **TMS** are sampled on the rising edge of **TCK** and all output transitions on **TDO** occur as a result of the falling edge of **TCK**.

10.6.1 EXTEST (00000)

The boundary scan (BS) register is placed in test mode by the EXTEST instruction.

The EXTEST instruction connects the BS register between **TDI** and **TDO**.

When the instruction register is loaded with the EXTEST instruction, all the boundary-scan cells are placed in their test mode of operation.

Boundary Scan Test Interface

In the CAPTURE-DR state, inputs from the system pins and outputs from the boundary-scan output cells to the system pins are captured by the boundary-scan cells. In the SHIFT-DR state, the previously captured test data is shifted out of the BS register via the **TDO** pin, while new test data is shifted in via the **TDI** pin to the BS register parallel input latch. In the UPDATE-DR state, the new test data is transferred into the BS register parallel output latch. Note that this data is applied immediately to the system logic and system pins.

10.6.2 SAMPLE/PRELOAD (00001)

The BS register is placed in normal (system) mode by the SAMPLE/PRELOAD instruction.

The SAMPLE/PRELOAD instruction connects the BS register between **TDI** and **TDO**.

When the instruction register is loaded with the SAMPLE/PRELOAD instruction, all the boundary-scan cells are placed in their normal system mode of operation.

In the CAPTURE-DR state, a snapshot of the signals at the boundary-scan cells is taken on the rising edge of **TCK**. Normal system operation is unaffected. In the SHIFT-DR state, the sampled test data is shifted out of the BS register via the **TDO** pin, while new data is shifted in via the **TDI** pin to preload the BS register parallel input latch. In the UPDATE-DR state, the preloaded data is transferred into the BS register parallel output latch. Note that this data is not applied to the system logic or system pins while the SAMPLE/PRELOAD instruction is active. This instruction should be used to preload the boundary-scan register with known data prior to selecting EXTEST instructions (see the table below for appropriate guard values to be used for each boundary-scan cell).

10.6.3 CLAMP (00100)

The CLAMP instruction connects a 1 bit shift register (the BYPASS register) between **TDI** and **TDO**.

When the CLAMP instruction is loaded into the instruction register, the state of all output signals is defined by the values previously loaded into the boundary-scan register. A guarding pattern (specified for this device at the end of this section) should be pre-loaded into the boundary-scan register using the SAMPLE/PRELOAD instruction prior to selecting the CLAMP instruction.

In the CAPTURE-DR state, a logic 0 is captured by the bypass register. In the SHIFT-DR state, test data is shifted into the bypass register via **TDI** and out via **TDO** after a delay of one **TCK** cycle. Note that the first bit shifted out will be a zero. The bypass register is not affected in the UPDATE-DR state.

10.6.4 HIGHZ (00101)

The HIGHZ instruction connects a 1 bit shift register (the BYPASS register) between **TDI** and **TDO**.

When the HIGHZ instruction is loaded into the instruction register, all outputs are placed in an inactive drive state.

In the CAPTURE-DR state, a logic 0 is captured by the bypass register. In the SHIFT-DR state, test data is shifted into the bypass register via **TDI** and out via **TDO** after a delay of one **TCK** cycle. Note that the first bit shifted out will be a zero. The bypass register is not affected in the UPDATE-DR state.

10.6.5 IDCODE (00110)

The IDCODE instruction connects the device identification register (or ID register) between **TDI** and **TDO**. The ID register is a 32-bit register that allows the manufacturer, part number and version of a component to be determined through the TAP.

When the instruction register is loaded with the IDCODE instruction, all the boundary-scan cells are placed in their normal (system) mode of operation.

In the CAPTURE-DR state, the device identification code (specified at the end of this section) is captured by the ID register. In the SHIFT-DR state, the previously captured device identification code is shifted out of the ID register via the **TDO** pin, while data is shifted in via the **TDI** pin into the ID register. In the UPDATE-DR state, the ID register is unaffected.

10.6.6 BYPASS (11111)

The BYPASS instruction connects a 1 bit shift register (the BYPASS register) between **TDI** and **TDO**.

When the BYPASS instruction is loaded into the instruction register, all the boundary-scan cells are placed in their normal (system) mode of operation. This instruction has no effect on the system pins.

In the CAPTURE-DR state, a logic 0 is captured by the bypass register. In the SHIFT-DR state, test data is shifted into the bypass register via **TDI** and out via **TDO** after a delay of one **TCK** cycle. Note that the first bit shifted out will be a zero. The bypass register is not affected in the UPDATE-DR state.

Boundary Scan Test Interface

10.7 Test Data Registers

Figure 10 illustrates the structure of the boundary scan logic.

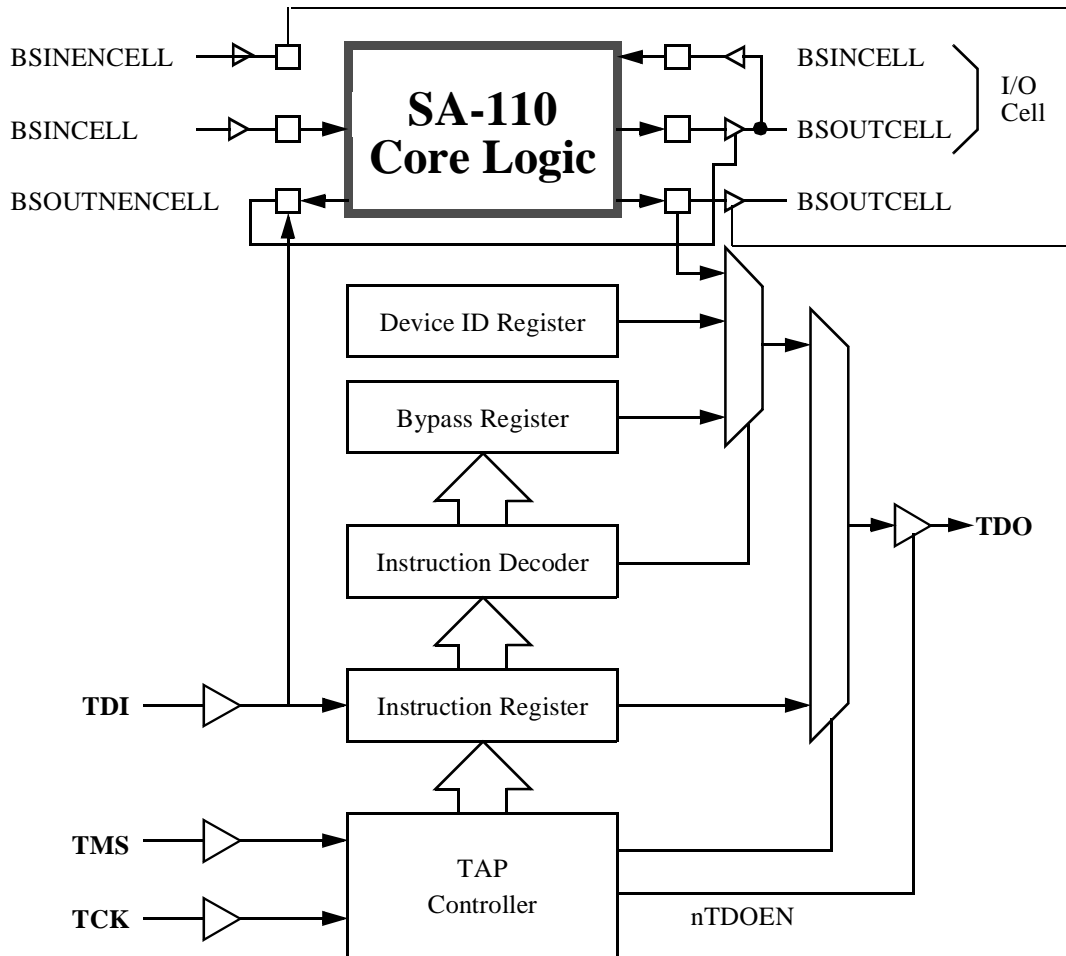

Figure 10: Boundary Scan Block Diagram

10.7.1 Bypass Register

Purpose: This is a single bit register which can be selected as the path between **TDI** and **TDO** to allow the device to be bypassed during boundary-scan testing.

Length: 1 bit

Operating Mode: When the **BYPASS** instruction is the current instruction in the instruction register, serial data is transferred from **TDI** to **TDO** in the **SHIFT-DR** state with a delay of one **TCK** cycle.

Boundary Scan Test Interface

There is no parallel output from the bypass register.

A logic 0 is loaded from the parallel input of the bypass register in the CAPTURE-DR state.

10.7.2 SA-110 Device Identification (ID) Code Register

Purpose: This register is used to read the 32-bit device identification code. No programmable supplementary identification code is provided.

Length: 32 bits

The format of the ID register is as follows:

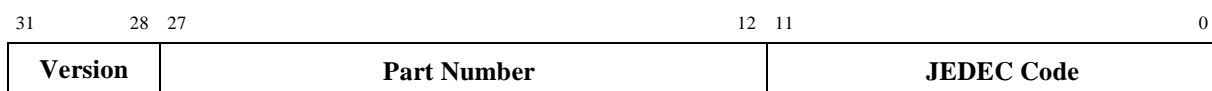

The high order four bits of the ID register are the version and bits 27..0 are 0x102C06B.

Operating Mode: When the IDCODE instruction is current, the ID register is selected as the serial path between **TDI** and **TDO**.

There is no parallel output from the ID register.

The 32-bit device identification code is loaded into the ID register from its parallel inputs during the CAPTURE-DR state.

10.7.3 SA-110 Boundary Scan (BS) Register

Purpose: The BS register consists of a serially connected set of cells around the periphery of the device, at the interface between the core logic and the system input/output pads. This register can be used to isolate the pins from the core logic and then drive or monitor the system pins.

Operating modes: The BS register is selected as the register to be connected between **TDI** and **TDO** only during the SAMPLE/PRELOAD, and EXTEST instructions. Values in the BS register are used, but are not changed, during the CLAMP instruction.

In the normal (system) mode of operation, straight-through connections between the core logic and pins are maintained and normal system operation is unaffected.

In TEST mode (when EXTEST is the currently selected instruction), values can be applied to the output pins independently of the actual values on the input pins and core logic outputs. On the SA-110 all of the boundary scan cells include an update register and thus all of the pins can be controlled in the above manner. An additional boundary-scan cell is interposed in the scan chain in order to control the enabling of the data bus.

Boundary Scan Test Interface

The correspondence between boundary-scan cells and system pins, system direction controls and system output enables is as shown in the Boundary Scan Signals & Pins table . The cells are listed in the order in which they are connected in the boundary-scan register, starting with the cell closest to **TDI**.

The EXTEST guard values specified in the Boundary Scan Signals & Pins table should be clocked into the boundary-scan register (using the SAMPLE/PRELOAD instruction) before the EXTEST instruction is selected, to ensure that known data is applied to the core logic during the test. This guard value should also be used when new EXTEST vectors are clocked into the boundary-scan register.

The values stored in the BS register after power-up are not defined. Similarly, the values previously clocked into the BS register are not guaranteed to be maintained across a Boundary Scan reset (from forcing **nTRST** low or entering the test logic reset state).

10.8 Boundary Scan Interface Signals

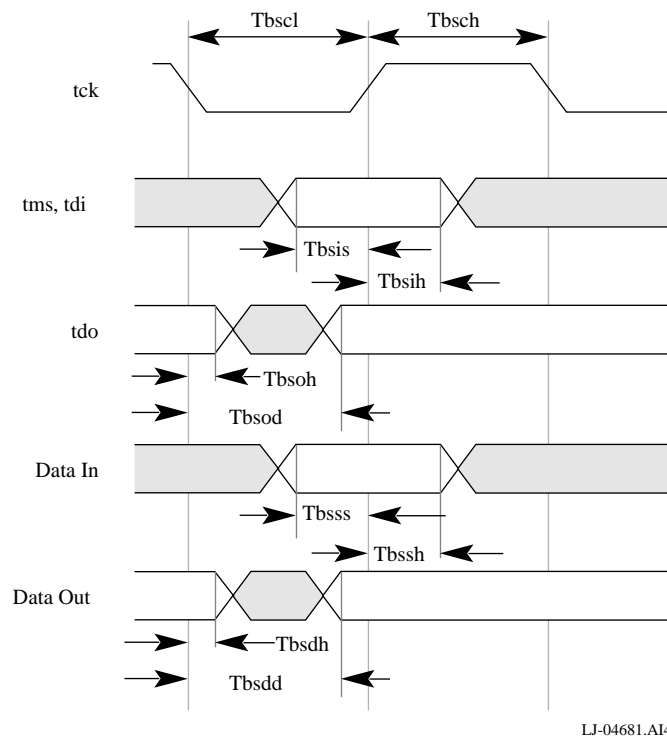

Figure 11: Boundary Scan General Timing

Boundary Scan Test Interface

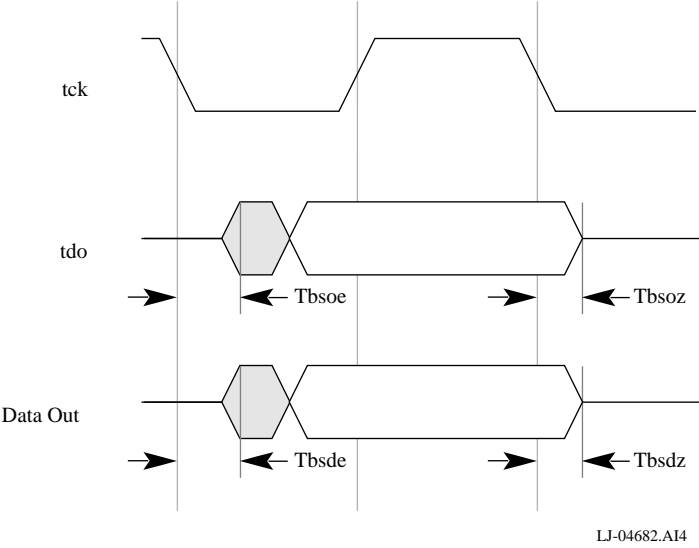

Figure 12: Boundary Scan Tri-state Timing

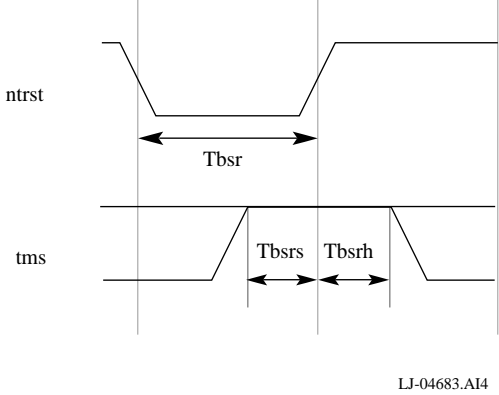

Figure 13: Boundary Scan Reset Timing

Boundary Scan Test Interface

Table 15: SA-110 Boundary Scan Interface Timing

Symbol	Parameter	Min	Max	Units	Notes
Tbscl	TCK low period	50		ns	9
Tbsch	TCK high period	50		ns	9
Tbsis	TDI,TMS setup to [TCr]	15		ns	
Tbsih	TDI,TMS hold from [TCr]	25		ns	
Tbsoh	TDO hold time	1		ns	1
Tbsod	TCf to TDO valid		40	ns	1
Tbsss	I/O signal setup to [TCr]	15		ns	4
Tbssh	I/O signal hold from [TCr]	25		ns	4
Tbsdh	data output hold time	1		ns	5
Tbsdd	TCf to data output valid		40	ns	
Tbsoe	TDO enable time	5		ns	1,2
Tbsoz	TDO disable time		40	ns	1,3
Tbsde	data output enable time	5		ns	5,6
Tbsdz	data output disable time		40	ns	5,7
Tbsr	Reset period	30		ns	
Tbsrs	tms setup to [TRr]	15		ns	9
Tbsrh	tms hold from [TRr]	25		ns	9

Notes:

1. Assumes a 25pF load on **TDO**. Output timing derates at 0.072ns/pF of extra load applied.
2. **TDO** enable time applies when the TAP controller enters the Shift-DR or Shift-IR states.
3. **TDO** disable time applies when the TAP controller leaves the Shift-DR or Shift-IR states.
4. For correct data latching, the I/O signals (from the core and the pads) must be setup and held with respect to the rising edge of **TCK** in the CAPTURE-DR state of the SAMPLE/PRELOAD and EXTEST instructions.
5. Assumes that the data outputs are loaded with the ac test loads (see ac parameter specification).
6. Data output enable time applies when the boundary scan logic is used to enable the output drivers.
7. Data output disable time applies when the boundary scan is used to disable the output drivers.
8. **TMS** must be held high as **nTRST** is taken high at the end of the boundary-scan reset sequence.
9. **TCK** may be stopped indefinitely in either the low or high phase.

Boundary Scan Test Interface

Table 16: Boundary Scan Signals & Pins

No.	Cell Name	Pin	Type	Output enable BS Cell	Guard Value EX
from tdi					
1	mse	MSE	IN	-	
2	config	CONFIG	IN	-	
3	nmreq	nMREQ	OUT	mse	
4	seq	SEQ	OUT	mse	
5	clf	CLF	OUT	abe	
6	lock	LOCK	OUT	abe	
7	nrw	nRW	OUT	abe	
8	spdf	SPDF	IN	-	
9	mccfg0	MCCFG[0]	IN	-	
10	mccfg1	MCCFG[1]	IN	-	
11	mccfg2	MCCFG[2]	IN	-	
12	cccfcg2	CCCFG[2]	IN	-	
13	cccfcg3	CCCFG[3]	IN	-	
14	nresetout	nRESET_OUT	OUT	-	
15	abe	ABE	IN	abe	
16	mas0	MAS[0]	OUT	abe	
17	mas1	MAS[1]	OUT	abe	
18	a0	A[0]	OUT	abe	
19	a1	A[1]	OUT	abe	
20	a2	A[2]	OUT	abe	
21	a3	A[3]	OUT	abe	
22	a4	A[4]	OUT	abe	
23	a5	A[5]	OUT	abe	
24	a6	A[6]	OUT	abe	
25	a7	A[7]	OUT	abe	
26	a8	A[8]	OUT	abe	
27	a9	A[9]	OUT	abe	
28	a10	A[10]	OUT	abe	
29	a11	A[11]	OUT	abe	
30	a12	A[12]	OUT	abe	
31	a13	A[13]	OUT	abe	
32	a14	A[14]	OUT	abe	
33	a15	A[15]	OUT	abe	
34	a16	A[16]	OUT	abe	
35	a17	A[17]	OUT	abe	
36	a18	A[18]	OUT	abe	
37	a19	A[19]	OUT	abe	
38	a20	A[20]	OUT	abe	
39	a21	A[21]	OUT	abe	
40	a22	A[22]	OUT	abe	
41	a23	A[23]	OUT	abe	
42	a24	A[24]	OUT	abe	
43	a25	A[25]	OUT	abe	
44	a26	A[26]	OUT	abe	
45	a27	A[27]	OUT	abe	
46	a28	A[28]	OUT	abe	

No.	Cell Name	Pin	Type	Output enable BS Cell	Guard Value EX
47	a29	A[29]	OUT	abe	
48	a30	A[30]	OUT	abe	
49	a31	A[31]	OUT	abe	
50	ape	APE	IN	-	
51	abort	ABORT	IN	-	
52	mclkin	MCLK	IN	-	
53	mclkout	MCLK	OUT	sna	
54	nmclk	NMCLK	OUT	sna	
55	nwait	nWAIT	IN	-	
56	clk	CLK	IN	-	
57	test_byp	TEST_BYP	IN	-	
58	testclk	TESTCLK	IN	-	
59	cccfcg1	CCCFG[1]	IN	-	
60	cccfcg0	CCCFG[0]	IN	-	
61	nreset	nRESET	IN	-	
62	sna	SnA	IN	-	
63	fiq	FIQ	IN	-	
64	irq	IRQ	IN	-	
65	din0	D[0]	IN	-	
66	dout0	D[0]	OUT	dbe	
67	din1	D[1]	IN	-	
68	dout1	D[1]	OUT	dbe	
69	din2	D[2]	IN	-	
70	dout2	D[2]	OUT	dbe	
71	din3	D[3]	IN	-	
72	dout3	D[3]	OUT	dbe	
73	din4	D[4]	IN	-	
74	dout4	D[4]	OUT	dbe	
75	din5	D[5]	IN	-	
76	dout5	D[5]	OUT	dbe	
77	din6	D[6]	IN	-	
78	dout6	D[6]	OUT	dbe	
79	din7	D[7]	IN	-	
80	dout7	D[7]	OUT	dbe	
81	din8	D[8]	IN	-	
82	dout8	D[8]	OUT	dbe	
83	din9	D[9]	IN	-	
84	dout9	D[9]	OUT	dbe	
85	din10	D[10]	IN	-	
86	dout10	D[10]	OUT	dbe	
87	din11	D[11]	IN	-	
88	dout11	D[11]	OUT	dbe	
89	din12	D[12]	IN	-	
90	dout12	D[12]	OUT	dbe	
91	din13	D[13]	IN	-	
92	dout13	D[13]	OUT	dbe	
93	din14	D[14]	IN	-	

11.0 dc Parameters

11.1 Absolute Maximum Ratings

Table 17: SA-110 dc Maximum Ratings

Symbol	Parameter	Minimum	Maximum	Units	Note
VDD	Core supply voltage	VSS – 0.5	VSS+2.2	V	1
VDDX	I/O voltage	MIN(VSS – 0.5, VDD – 0.3)	VSS+3.6	V	1
Vip	Voltage applied to any pin	VSS – 0.3	MIN(VDDX +0.3, VSS +3.6)	V	1
Ts	Short-term storage temperature	–20	125	°C	1

Note: (1) These are stress SA-110 ratings only. Exceeding the absolute maximum ratings may permanently damage the device.

11.2 dc Operating Conditions

Table 18: SA-110 dc Operating Conditions

Symbol	Parameter	Minimum	Maximum	Units	Notes
Vihc	IC input high voltage	0.8 * VDDX	VDDX	V	1,2
Vilc	IC input low voltage	0.0	0.2 * VDDX	V	1,2
Vohc	OCZ output high voltage at –2 mA	0.8 * VDDX	VDDX	V	1,2,3
Volc	OCZ output low voltage at 2 mA	0.0	0.2 * VDDX	V	1,2,3
Iohc	High-level output current	—	–2 mA	mA	3
Iolc	Low-level output current	—	2 mA	mA	3
Ta	Ambient operating temperature	0	70	°C	

Notes: (1) Voltages measured with respect to VSS.
 (2) IC - CMOS-level inputs (includes IC and ICOCZ pin types).
 (3) In sleep mode, the levels on the output and I/O pins are maintained by weak leakers only. Systems that require the SA-110 to sink or source dc current may not use sleep mode.

dc Parameters

11.3 dc Characteristics

Table 19: SA-110 dc Characteristics

Symbol	Parameter	Nominal	Units
I _{in}	IC input leakage current	100	μA
I _{ts}	Tristate leakage current	100	μA
C _{in}	Input pin capacitance	5	pF
C _{io}	Input /output pin capacitance	12	pF
ESD	HBM human body model	1	kV

11.4 Power Supply Voltages and Currents

Table 20: SA-110 Power Supply Voltages and Currents

Parameter	21281					Units	Notes
	AA	BA	CA	DA	EA		
Maximum normal mode power	450	300	900	700	1000	mW	1
Maximum idle power	20	20	n/a	n/a	n/a	mW	2
Maximum sleep mode current	50	50	n/a	n/a	n/a	μA	2
VDD							
Minimum internal power supply voltage	1.5	1.5	1.8	1.8	1.9	V	
Nominal internal power supply voltage	1.65	1.65	2.0	2.0	2.0	V	
Maximum internal power supply voltage	1.8	1.8	2.2	2.2	2.1	V	
VDDX							
Minimum external power supply voltage	3.0	3.0	3.0	3.0	3.0	V	
Nominal external power supply voltage	3.3	3.3	3.3	3.3	3.3	V	
Maximum external power supply voltage	3.6	3.6	3.6	3.6	3.6	V	

- Notes: (1) Running Dhrytone 2.1 at 25°C, nominal power supply voltages, and 20 pF load on output and I/O pins. Power for AA, BA, and DA parts assumes 33-MHz external bus. Power for CA and EA parts assumes 66-MHz external bus.
- (2) Measured at 25°C junction temperature. Since the power levels for these modes are low, the junction temperature and ambient temperature are nearly equal during sleep and idle.

12.0 ac Parameters

12.1 Test Conditions

The ac timing diagrams presented in this section assume that the outputs of the SA-110 have been loaded with a 50pF capacitive load on outut signals and 15pF load on clock outputs. The output pads of the SA-110 are CMOS drivers which exhibit a propagation delay that increases with the increase in load capacitance. An 'output derating' figure is given for each output pad, showing the approximate rate of increase of delay with increasing or decreasing load capacitance for typical process at room temperature.

Table 21: SA-110 Output Derating

Output Signal	Load for Nominal Value	Output Derating (ns/pF) VDD=1.65 Rising Edge	Output Derating (ns/pF) VDD=1.65 Falling Edge	Output Derating (ns/pF) VDD=2.0 Rising Edge	Output Derating (ns/pF) VDD=2.0 Falling Edge
A[31:0], nR/W, LOCK, nMREQ, SEQ, D[31:0]	50pf	.07	.09	.07	.07
nMCLK, MCLK	15pf	.03	.04	.03	.03

12.2 Module Considerations

The edge rates for the SA-110 are such that the lumped load model presented above can only be used for etch lengths up to 1 inch. Over one inch of etch the signal is a transmission line and needs to be modeled as such.

ac Parameters

12.3 Main Bus Signals

The **MCLK** signal is the reference for all SA-110 timing. The **nMCLK** signal is an inverted copy of the **MCLK** signal when **SnA** is high. The **nMCLK** signal is low when **SnA** is low. The SA-110 will stall its internal clock for one cycle if **nWAIT** is low when **MCLK** goes high.

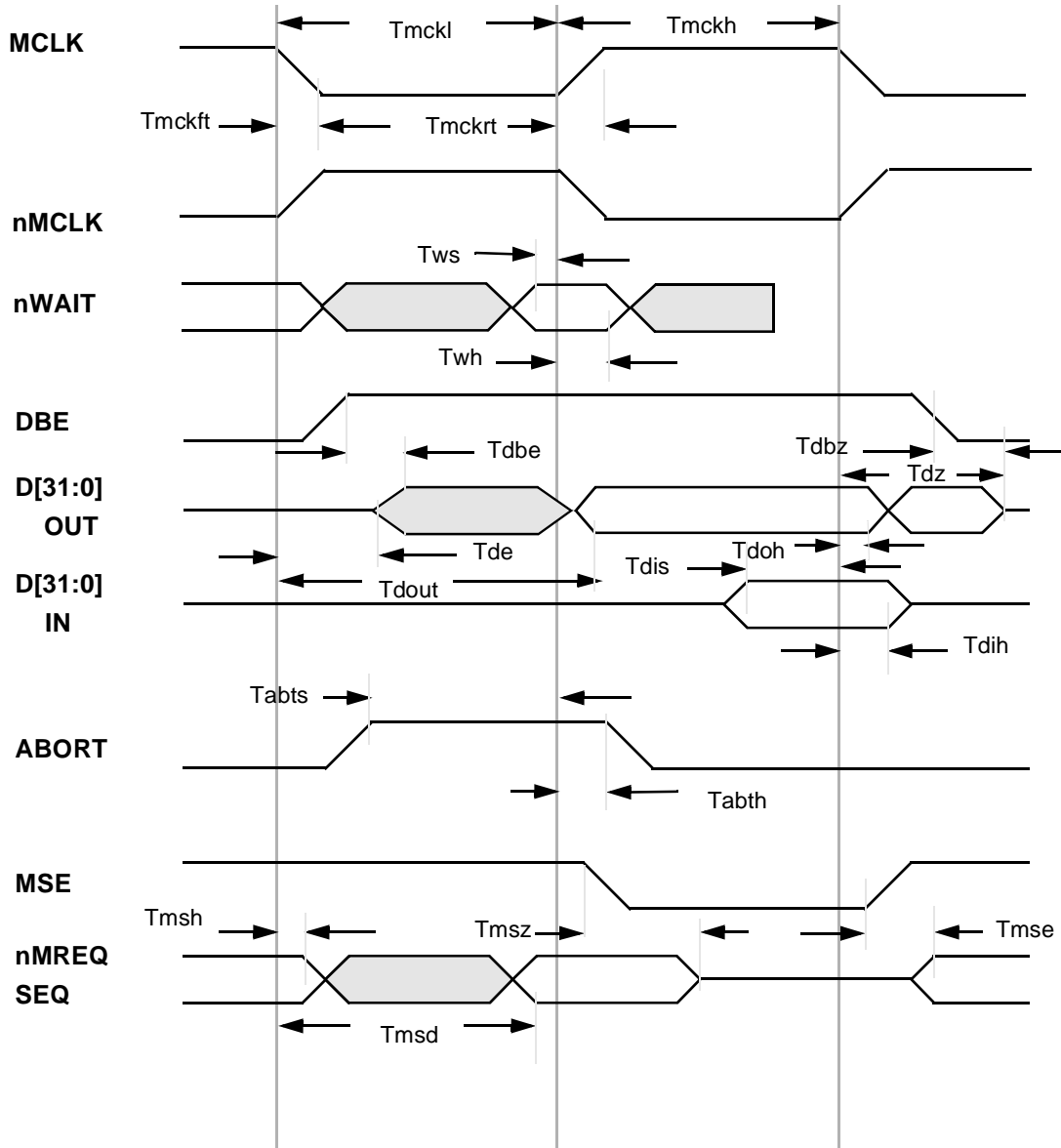

Figure 14: SA-110 Main Bus Timing

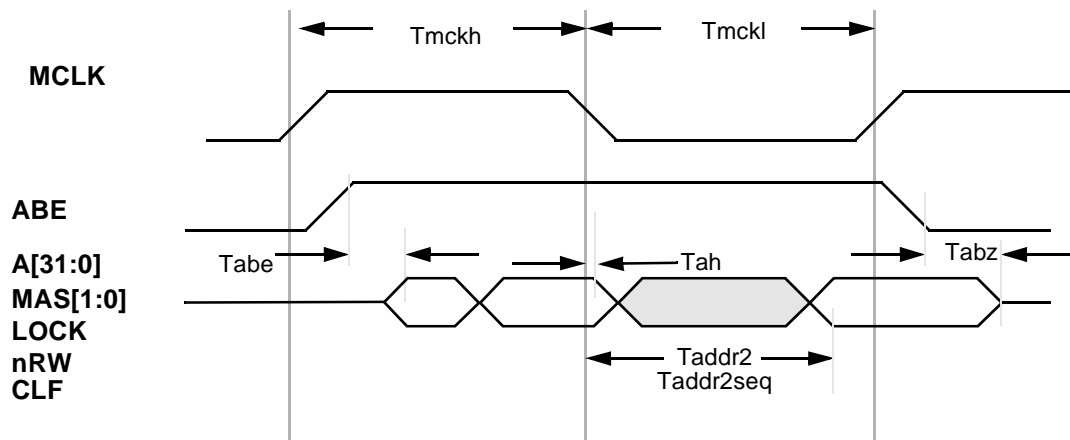

Figure 15: SA-110 Address Timing with APE=Low

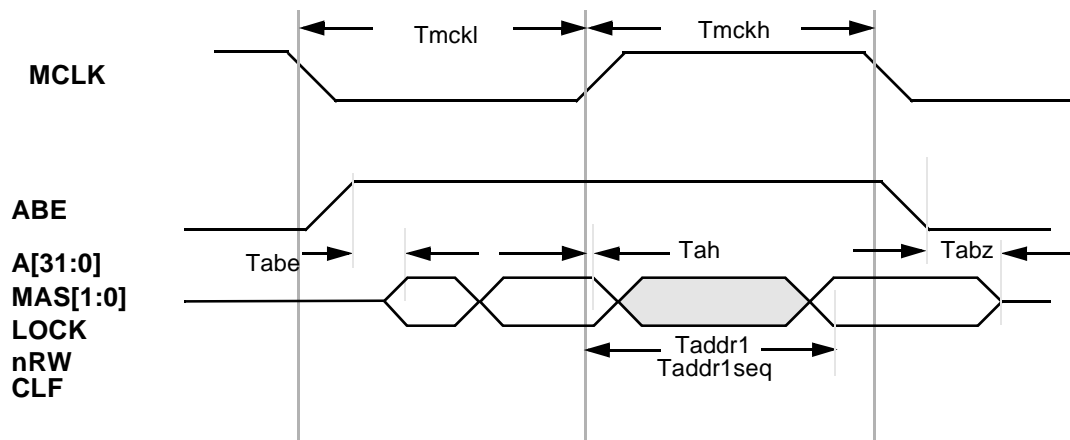

Figure 16: SA-110 Address Timing with APE=HIGH

ac Parameters

12.4 SA-110 ac Parameters

The ac parameters specified in the following tables are valid for the full range of voltage, temperature, and process defined for each SA-110 part in Table 20.

The following notes are used in Tables 22–26.

- 1) **MCLK** and **nMCLK** timings measured between clock edges at 50% of **VDDX** driving 15 pF load.
- 2) The timings of these signals are measured to 80%/20% for outputs and 90%/10% for inputs.
- 3) The **Taddrx** times are for the first address of a sequential cycle. The **Taddrxseq** times are for the subsequent addresses of a sequential cycle.
- 4) The **MCCFG** setting with **SnA** asserted should be selected so the nominal **MCLK** speed does not exceed $1/(2 * Tmckh)$.
- 5) **Tdoh** is guaranteed to be greater than a minimum **Tdz**.

Table 22: SA-110 ac for –AA Parts

Symbol	Parameter	Min	Max	Unit	Note
Tmckl	MCLK LOW time	10		ns	1
Tmckh	MCLK HIGH time	10		ns	1
Tmckrt	MCLK , nMCLK rise time SnA=1	.75	2	ns	1
Tmckft	MCLK , nMCLK fall time SnA=1	1	3	ns	1
CCCFCG	CCCFCG setting	0	6	value	4
Tmckr	MCLK rise to nMCLK fall SnA=1	-0.5	1.5	ns	1
Tmckf	MCLK fall to nMCLK rise SnA=1	-1.5	0.5	ns	1
Tws	nWAIT setup to MCLK	1		ns	2
Twh	nWAIT hold from MCLK	2		ns	2
Tabe	address bus enable		11	ns	2
Tabz	address bus disable		4	ns	2
Taddr1	MCLK to address delay APE high		15	ns	2,3
Taddr2	MCLK to address delay APE low		10	ns	2,3
Taddr1seq	MCLK to address delay APE high		10	ns	2,3
Taddr2seq	MCLK to address delay APE low		10	ns	2,3
Tah	address hold time	2		ns	2
Tdbe	DBE to data enable		10	ns	2
Tde	MCLK to data enable	3		ns	2
Tdbz	DBE to data disable		4	ns	2
Tdz	MCLK to data disable		8	ns	2,5
Tdout	data out delay		11	ns	2
Tdoh	data out hold	2		ns	2
Tdis	data in setup	0		ns	2
Tdih	data in hold	2		ns	2
Tabts	ABORT setup time	1		ns	2
Tabth	ABORT hold time	2		ns	2
Tmse	nMREQ & SEQ enable		9	ns	2
Tmsz	nMREQ & SEQ disable		3	ns	2
Tmsd	nMREQ & SEQ delay		11	ns	2
Tmsh	nMREQ & SEQ hold	2		ns	2

ac Parameters

Table 23: SA-110 ac for –BA Parts

Symbol	Parameter	Min	Max	Unit	Note
Tmckl	MCLK low time	15		ns	1
Tmckh	MCLK HIGH time	15		ns	1
Tmckrt	MCLK, nMCLK rise time SnA=1	.75	3	ns	1
Tmckft	MCLK, nMCLK fall time SnA=1	1	3.5	ns	1
CCCFG	CCCFG setting	0	2	value	4
Tmckr	MCLK rise to nMCLK fall SnA=1	-1	2	ns	1
Tmckf	MCLK fall to nMCLK rise SnA=1	-2	.5	ns	1
Tws	nWAIT setup to MCLK	2		ns	2
Twh	nWAIT hold from MCLK	3		ns	2
Tabe	address bus enable		15	ns	2
Tabz	address bus disable		6	ns	2
Taddr1	MCLK to address delay APE high		23	ns	2,3
Taddr2	MCLK to address delay APE low		13	ns	2,3
Taddr1seq	MCLK to address delay APE high		15	ns	2,3
Taddr2seq	MCLK to address delay APE low		13	ns	2,3
Tah	address hold time	2		ns	2
Tdbe	DBE to data enable		14	ns	2
Tde	MCLK to data enable	3		ns	2
Tdbz	DBE to data disable		5	ns	2
Tdz	MCLK to data disable		11	ns	2,5
Tdout	data out delay		15	ns	2
Tdoh	data out hold	2		ns	2
Tdis	data in setup	2		ns	2
Tdih	data in hold	3		ns	2
Tabts	ABORT setup time	2		ns	2
Tabth	ABORT hold time	3		ns	2
Tmse	nMREQ & SEQ enable		13	ns	2
Tmsz	nMREQ & SEQ disable		4	ns	2
Tmsd	nMREQ & SEQ delay		15	ns	2
Tmsh	nMREQ & SEQ hold	2		ns	2

Table 24: SA-110 ac for –CA Parts

Symbol	Parameter	Mfin	Max	Unit	Note
Tmckl	MCLK LOW time	7.5		ns	1
Tmckh	MCLK HIGH time	7.5		ns	1
Tmckrt	MCLK , nMCLK rise time SnA=1	.75	2	ns	1
Tmckft	MCLK , nMCLK fall time SnA=1	.75	2.5	ns	1
CCCFCG	CCCFCG setting	0	9	value	4
Tmckr	MCLK rise to nMCLK fall SnA=1	-1	1	ns	1
Tmckf	MCLK fall to nMCLK rise SnA=1	-1	1	ns	1
Tws	nWAIT setup to MCLK	1		ns	2
Twh	nWAIT hold from MCLK	2		ns	2
Tabe	address bus enable		10	ns	2
Tabz	address bus disable		4	ns	2
Taddr1	MCLK to address delay APE high		13	ns	2,3
Taddr2	MCLK to address delay APE low		9	ns	2,3
Taddr1seq	MCLK to address delay APE high		9	ns	2,3
Taddr2seq	MCLK to address delay APE low		9	ns	2,3
Tah	address hold time	2		ns	2
Tdbe	DBE to data enable		9	ns	2
Tde	MCLK to data enable	3		ns	2
Tdbz	DBE to data disable		3	ns	2
Tdz	MCLK to data disable		7	ns	2,5
Tdout	data out delay		10	ns	2
Tdoh	data out hold	2		ns	2
Tdis	data in setup	0		ns	2
Tdih	data in hold	2		ns	2
Tabts	ABORT setup time	1		ns	2
Tabth	ABORT hold time	2		ns	2
Tmse	nMREQ & SEQ enable		8	ns	2
Tmsz	nMREQ & SEQ disable		3	ns	2
Tmsd	nMREQ & SEQ delay		10	ns	2
Tmsh	nMREQ & SEQ hold	2		ns	2

ac Parameters

Table 25: SA-110 ac for –DA Parts

Symbol	Parameter	Min	Max	Unit	Note
Tmckl	MCLK low time	10		ns	1
Tmckh	MCLK HIGH time	10		ns	1
Tmckrt	MCLK, nMCLK rise time SnA=1	.75	3	ns	1
Tmckft	MCLK, nMCLK fall time SnA=1	.75	2.5	ns	1
CCCFG	CCCFG setting	0	7	value	4
Tmckr	MCLK rise to nMCLK fall SnA=1	-1.5	1	ns	1
Tmckf	MCLK fall to nMCLK rise SnA=1	-1	1.5	ns	1
Tws	nWAIT setup to MCLK	2		ns	2
Twh	nWAIT hold from MCLK	3		ns	2
Tabe	address bus enable		13	ns	2
Tabz	address bus disable		5	ns	2
Taddr1	MCLK to address delay APE high		19	ns	2,3
Taddr2	MCLK to address delay APE low		12	ns	2,3
Taddr1seq	MCLK to address delay APE high		13	ns	2,3
Taddr2seq	MCLK to address delay APE low		12	ns	2,3
Tah	address hold time	2		ns	2
Tdbe	DBE to data enable		13	ns	2
Tde	MCLK to data enable	3		ns	2
Tdbz	DBE to data disable		5	ns	2
Tdz	MCLK to data disable		9	ns	2,5
Tdout	data out delay		14	ns	2
Tdoh	data out hold	2		ns	2
Tdis	data in setup	2		ns	2
Tdih	data in hold	3		ns	2
Tabts	ABORT setup time	2		ns	2
Tabth	ABORT hold time	3		ns	2
Tmse	nMREQ & SEQ enable		12	ns	2
Tmsz	nMREQ & SEQ disable		3	ns	2
Tmsd	nMREQ & SEQ delay		14	ns	2
Tmsh	nMREQ & SEQ hold	2		ns	2

Table 26: SA-110 ac for –EA Parts

Symbol	Parameter	Mfin	Max	Unit	Note
Tmckl	MCLK LOW time	7.5		ns	1
Tmckh	MCLK HIGH time	7.5		ns	1
Tmckrt	MCLK , nMCLK rise time SnA=1	.75	2	ns	1
Tmckft	MCLK , nMCLK fall time SnA=1	.75	2.5	ns	1
CCCFCG	CCCFCG setting	0	12	value	4
Tmckr	MCLK rise to nMCLK fall SnA=1	-1	1	ns	1
Tmckf	MCLK fall to nMCLK rise SnA=1	-1	1	ns	1
Tws	nWAIT setup to MCLK	1		ns	2
Twh	nWAIT hold from MCLK	2		ns	2
Tabe	address bus enable		10	ns	2
Tabz	address bus disable		4	ns	2
Taddr1	MCLK to address delay APE high		13	ns	2,3
Taddr2	MCLK to address delay APE low		9	ns	2,3
Taddr1seq	MCLK to address delay APE high		9	ns	2,3
Taddr2seq	MCLK to address delay APE low		9	ns	2,3
Tah	address hold time	2		ns	2
Tdbe	DBE to data enable		9	ns	2
Tde	MCLK to data enable	3		ns	2
Tdbz	DBE to data disable		3	ns	2
Tdz	MCLK to data disable		7	ns	2,5
Tdout	data out delay		10	ns	2
Tdoh	data out hold	2		ns	2
Tdis	data in setup	0		ns	2
Tdih	data in hold	2		ns	2
Tabts	ABORT setup time	1		ns	2
Tabth	ABORT hold time	2		ns	2
Tmse	nMREQ & SEQ enable		8	ns	2
Tmsz	nMREQ & SEQ disable		3	ns	2
Tmsd	nMREQ & SEQ delay		10	ns	2
Tmsh	nMREQ & SEQ hold	2		ns	2

13.0 Physical Details

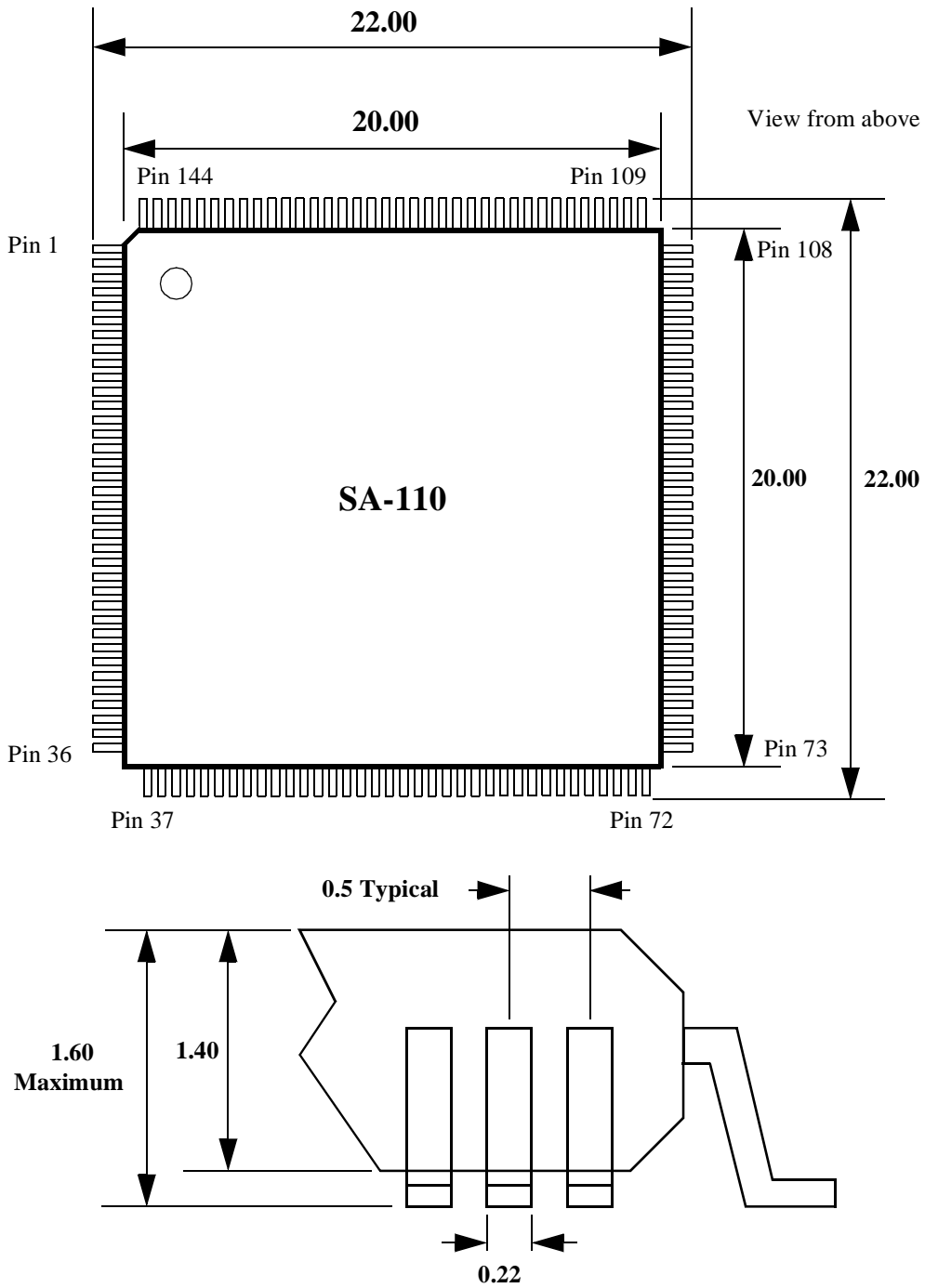

Figure 17: SA-110 144-Pin TQFP Mechanical Dimensions in mm

13.1 Pinout

Table 27: SA-110 Pinout – 144 pin Thin Quad Flat Pack

Pin	Signal	Type	Pin	Signal	Type	Pin	Signal	Type	Pin	Signal	Type
1	D[0]	I/O	37	D[23]	I/O	73	MAS[0]	O	109	A[22]	O
2	D[1]	I/O	38	D[24]	I/O	74	MAS[1]	O	110	A[23]	O
3	D[2]	I/O	39	D[25]	I/O	75	A[0]	O	111	A[24]	O
4	D[3]	I/O	40	D[26]	I/O	76	A[1]	O	112	A[25]	O
5	VDD	–	41	D[27]	I/O	77	A[2]	O	113	VSS	–
6	VSS	–	42	VSS	–	78	VDDX2	–	114	VDDX2	–
7	VSS	–	43	VDDX1	–	79	VSS	–	115	A[26]	O
8	VDDX1	–	44	D[28]	I/O	80	VSS	–	116	A[27]	O
9	D[4]	I/O	45	D[29]	I/O	81	VDD	–	117	A[28]	O
10	D[5]	I/O	46	D[30]	I/O	82	A[3]	O	118	A[29]	O
11	D[6]	I/O	47	D[31]	I/O	83	A[4]	O	119	A[30]	O
12	D[7]	I/O	48	TDO	O	84	A[5]	O	120	A[31]	O
13	D[8]	I/O	49	TDI	I	85	A[6]	O	121	APE	I
14	D[9]	I/O	50	nTRST	I	86	A[7]	O	122	ABORT	I
15	D[10]	I/O	51	TMS	I	87	A[8]	O	123	MCLK	I/O
16	D[11]	I/O	52	TCK	I	88	A[9]	O	124	nMCLK	O
17	VDDX1	–	53	n/c		89	A[10]	O	125	VSS	–
18	VSS	–	54	VSS	–	90	VDD	–	126	VDDX2	–
19	VSS	–	55	VDD	–	91	VSS	–	127	nWAIT	I
20	VDD	–	56	MSE	I	92	VSS	–	128	CLK	I
21	D[12]	I/O	57	CONFIG	I	93	VDDX2	–	129	VDD	–
22	D[13]	I/O	58	nMREQ	O	94	A[11]	O	130	TCK_BYP	I
23	D[14]	I/O	59	SEQ	O	95	A[12]	O	131	TESTCLK	I
24	D[15]	I/O	60	CLF	O	96	A[13]	O	132	VSS	–
25	D[16]	I/O	61	LOCK	O	97	A[14]	O	133	VDD	–
26	D[17]	I/O	62	nRW	O	98	A[15]	O	134	n/c	
27	D[18]	I/O	63	VSS	–	99	A[16]	O	135	n/c	
28	D[19]	I/O	64	VDDX1	–	100	A[17]	O	136	n/c	
29	VDDX1	–	65	SPDF	I	101	A[18]	O	137	n/c	
30	VSS	–	66	MCCFG[0]	I	102	VDDX2	–	138	CCCFG[1]	I
31	VSS	–	67	MCCFG[1]	I	103	VSS	–	139	CCCFG[0]	I
32	VDD	–	68	MCCFG[2]	I	104	VSS	–	140	nPWRSLP	I
33	D[20]	I/O	69	CCCFG[2]	I	105	VDD	–	141	nRESET	I
34	D[21]	I/O	70	CCCFG[3]	I	106	A[19]	O	142	SnA	I
35	D[22]	I/O	71	nRESET_OUT	O	107	A[20]	O	143	nFIQ	I
36	DBE	I	72	ABE	I	108	A[21]	O	144	nIRQ	I

Note: **VDDX1** and **VDDX2** should be tied to the **VDDX** power plane of the system, but are not internally connected.

Support, Products and Documentation

If you need technical support or help deciding which literature best meets your needs, call the **Digital Semiconductor Information Line**:

United States and Canada **1-800-332-2717**
Outside North America **+1-510-490-4753**

or visit the Digital Semiconductor World-Wide Web Internet site:

<http://www.digital.com/info/semiconductor>

Ordering Digital Semiconductor Products

To order the Digital Semiconductor SA-110 microprocessor and for more information about an evaluation board kit, contact your local distributor.

The following table lists some of the semiconductor products available from Digital. To obtain a *Digital Semiconductor Product Catalog*, call the Digital Semiconductor Information Line.

Product	Order Number
Digital Semiconductor SA-110 Microprocessor (100 MHz)	21281-BA
Digital Semiconductor SA-110 Microprocessor (160 MHz)	21281-AA
Digital Semiconductor SA-110 Microprocessor (200 MHz)	21281-CA
Digital Semiconductor SA-110 Microprocessor (166 MHz)	21281-DA
Digital Semiconductor SA-110 Microprocessor (233 MHz)	21281-EA
Digital Semiconductor SA-110 Hardware Developer's Kit	21A81-11
ARM Software Developer's Kit – End User License	21B81-01
ARM Software Developer's Kit – Site License	21B81-02

Ordering Associated Digital Semiconductor Literature

The following table lists some of the available Digital Semiconductor literature. For a complete list, call the Digital Semiconductor Information Line.

Title	Order Number
Digital Semiconductor SA-110 Microprocessor Product Brief	EC-QPWKC-TE
Digital Semiconductor SA-110 Microprocessor Tools Brochure	EC-QPWJB-TE
Digital Semiconductor SA-110 Evaluation Board Reference Manual	EC-QU5KA-TE
ARM Architecture Reference	EC-QV44A-TE

Ordering Third-Party Literature

You can order the following third-party literature directly from the vendor:

Title	Vendor
IEEE Standard 1149.1 – 1990, Standard Test Access Port and Boundary-Scan Architecture	The Institute of Electrical and Electronics Engineers, Inc. U.S. 1-800-701-4333 International 1-908-981-0060 FAX 1-908-981-9667

